

**Mexico**

**Family Formation Patterns and  
Child Mortality in Mexico**

**José Luis Bobadilla  
Loraine Schlaepfer  
Javier Alagón**

**Centro de Investigaciones en Salud Pública  
Instituto Nacional de Salud Pública**

**The Population Council**



**Demographic and Health Surveys  
Institute for Resource Development/Macro Systems, Inc.**

MEXICO

# Family Formation Patterns and Child Mortality in Mexico

José Luis Bobadilla  
Loraine Schlaepfer  
Javier Alagón

Centro de Investigaciones en Salud Pública  
Instituto Nacional de Salud Pública  
México, D. F., México

Demographic and Health Surveys Further Analysis Series  
Number 5  
March 1990

## PREFACE

The Demographic and Health Surveys (DHS) Program was initiated in September 1984 and designed as a follow-on to the World Fertility Survey (WFS) and Contraceptive Prevalence Surveys (CPS). The objectives of the program include the expansion of the international population and health data base in Africa, Asia, and Latin America to assist in policy formulation and implementation and the development of skills and resources in survey design and analysis among those working in the program.

With funding provided by the U.S. Agency for International Development, DHS is implemented by the Institute for Resource Development/Macro Systems, Inc. and the Population Council, a major subcontractor. The Population Council, an international nonprofit organization established in 1952, undertakes social and health science programs and research relevant to developing countries and conducts biomedical research to develop and improve contraceptive technology. The Council provides advice and technical assistance to governments, international agencies, and nongovernmental organizations, and it disseminates information on population issues through publications, conferences, seminars, and workshops.

The Population Council was responsible for the establishment, funding, and provision of technical assistance to as many as 25 further analysis studies, in countries where DHS surveys were conducted during the years 1986 and 1987. The studies focus on one or more of the topics covered in the DHS survey, such as fertility, contraception, maternal and child health, breastfeeding, marriage and fertility preferences; their interrelationships, for example, the effects of the proximate determinants of fertility and the determinants of contraceptive use or child survival; and their correlation with background variables. Although the principal source of data is the DHS survey, comparisons with previous WFS, CPS, or other surveys in order to examine trends over time are included in some of the studies.

Information on the DHS Program can be obtained by writing to: DHS Program, IRD/Macro, 8850 Stanford Boulevard, Suite 4000, Columbia, Maryland 21045, USA (Telephone: 301-290-2800; Telex: 87775; Fax: 301-290-2999). For copies of the studies published in the DHS Further Analysis series, which are listed on the last page, write to the DHS Program, The Population Council, One Dag Hammarskjold Plaza, New York, New York 10017 USA.

## CONTENTS

	Page Nos.
ABSTRACT	iii
ACKNOWLEDGMENTS	iii
I. BACKGROUND AND JUSTIFICATION	1
II. PRIMARY GOALS AND SPECIFIC OBJECTIVES	2
III. GENERAL METHODOLOGY	2 - 7
Sources of Information	2
The National Fertility and Health Survey (ENFES, 1987)	
Vital Statistics	
Study Population	3
Analysis	3 - 7
Quality of Information on Mortality	
Relationship between Family Formation Patterns and Mortality	
IV. RESULTS AND DISCUSSION	7 - 21
Quality of the Data	7 - 8
Late Fetal Mortality	
Childhood Deaths	
The Patterns of Family Formation in Mexico	8 - 10
Distribution and Time Trends	
Comparison with Family Formation Patterns of Other Latin American Countries	
Mother's Education	
Community Size	
The Determinants of Child Mortality	10 - 11
Levels and Trends of Infant Mortality	
Correlates of Child Mortality	11 - 16
Age of the Mother at Birth	
Birth Order	
Reproductive Pace	
Interbirth Interval with a Previous Sibling	
The Effects of Family Formation Patterns on Child Mortality Patterns: Crude Associations	16 - 26
Late Fetal Mortality Rates	
Neonatal and Postneonatal Mortality Rates	
Infant and Child Mortality Rates	
Births to Teenagers	
Births to Women Aged 20-34 Years	
Births to Older Women	
Multivariate Analyses	26 - 29
Infant Mortality	
Neonatal and Postneonatal Mortality	
Childhood Mortality	
Comparison with 18 Developing Countries	29 - 32
Young Age	
Birth Intervals	
Reproductive Pace	

V. CONCLUSIONS AND POLICY IMPLICATIONS	32 - 34
Conclusions	32
Policy Implications	33 - 34
REFERENCES	35 - 36
APPENDIX A: Definitions of Terms	37 - 40
APPENDIX B: Tables	41 - 63

## ABSTRACT

The aim of the present project was to determine the effects of variations in the family formation patterns of Mexican women on late fetal and child mortality. The study consisted of a secondary analysis of the National Fertility and Health Survey conducted in 1987. The study population included 13,216 births occurring in the 15 years prior to the survey. Hobcraft's typology of the family formation patterns was adopted and adapted. Variations in the family formation patterns and in their relationship with late fetal, neonatal, postneonatal, infant and child mortality were analyzed over time and across a number of social variables. Contingency tables and logistic regression techniques were employed for the bivariate and multivariate analyses, respectively.

The following are the main conclusions of the study: 1) The groups with the highest late fetal mortality rates are poorly-spaced births to 20-34 year old women with a medium or fast reproductive pace and births to older women age 35 years of age and above; 2) infant mortality among births to teenage mothers is higher than average, only if poorly-spaced. This seems to reflect the sociocultural disadvantages of this group of mothers; 3) infant mortality rates of births to mothers aged 20-34 years increase as the reproductive pace changes from slow to medium to fast and birth spacing with the previous sibling changes from more than 24 months to fewer months; 4) births to women age 35 or above have an infant mortality rate equal to the population average; 5) the estimated effects of childhood mortality reveal striking similarity with those of infant mortality; and 6) important inverse relationships were found between mortality in all periods studied and socioeconomic variables, such as education and size of the community of residence of the mother. It is suggested that further reductions in fertility levels in the Mexican population would result in a continued increase in the proportion of births to mothers with favorable reproductive patterns and, therefore, in a further reduction of infant mortality rates.

## ACKNOWLEDGMENTS

We would like to acknowledge the invaluable help of Ms. Ma. de los Angeles Valdez, Director of Demographic and Social Statistics, and her staff and Ms. Teresa Delgado, Head of the Department of Vital Statistics in the Federal District; the assistance of INEGI; of Dr. Miguel Angel Lezana, Director of Information and Computing of the General Directorate of Epidemiology of the Ministry of Health; as well as Prof. Alejandro Lona and Mr. Manuel Recio of the National Institute of Public Health. These individuals made possible the creation of a file of the necessary vital statistics.

Adriana Ramírez and Bernardo Hernández of the National Institute of Public Health were responsible for data management and most of the programming. Their participation in the preparation of this report was invaluable. Special thanks are due to Veronica Lozano for her assistance in the typing of the manuscript and the elaboration of tables and figures.

We would also like to express our appreciation for the financial support received from the Population Council, which made this research project possible. In particular, we would like to thank Paula Hollerbach for her comments during the elaboration of the research proposal and her suggestions for improving the final version of the manuscript.



The research project reported on in this issue is "The Effects of Family Formation Patterns on Perinatal and Childhood Mortality." For further information on this work, write to the principal investigators, José Luis Bobadilla, M.D., Ph.D., Loraine Schlaepfer, Ph.D., and Javier Alagón, Ph.D., Instituto Nacional de Salud Pública, Centro de Investigaciones en Salud Pública, Av. Universidad 115, Col. Sta. Maria Ahacatlán, C.P. 62508 Cuernavaca, Morelos, México.

---

### Demographic and Health Surveys Further Analysis Series

1. "Health and Population Studies Based on the 1987 Thailand Demographic and Health Survey"  
Institute of Population Studies, Chulalongkorn University  
December 1989
  
2. "Population Studies in Sri Lanka and Indonesia Based on the 1987 Sri Lanka Demographic and Health Survey and The 1987 Indonesia National Contraceptive Prevalence Survey"  
March 1990  
  
"Traditional Contraceptive Use in Sri Lanka: A Cross Survey Analysis"  
Soma Silva, Victor de Silva, and A.T.P.L. Abeykoon, The Family Planning Association of Sri Lanka  
  
"Fertility Transition in Indonesia: Trends in Proximate Determinants of Fertility"  
Sri Moertiningsih Adioetomo, Ayke S. Kitting, and Saulman Taufik, Demographic Institute,  
Faculty of Economics, University of Indonesia  
  
"Correlates of Method Choice in Indonesia"  
John W. Molneaux, Charles Lerman, E. Srihartati P. Pandi, and Soni Trisno Wibisono,  
Badan Koordinasi Keluarga Berencana Nasional
  
3. "Breastfeeding and Diarrhea in Brazilian Children"  
Fernando C. Barros and Cesar G. Victora  
Department of Social Medicine, Universidade Federal de Pelotas  
March 1990
  
4. "Selection, Change, and Discontinuation of Contraceptive Methods in Trinidad and Tobago"  
Norma Abdulah, Institute of Social and Economic Research, the University of the West Indies  
March 1990



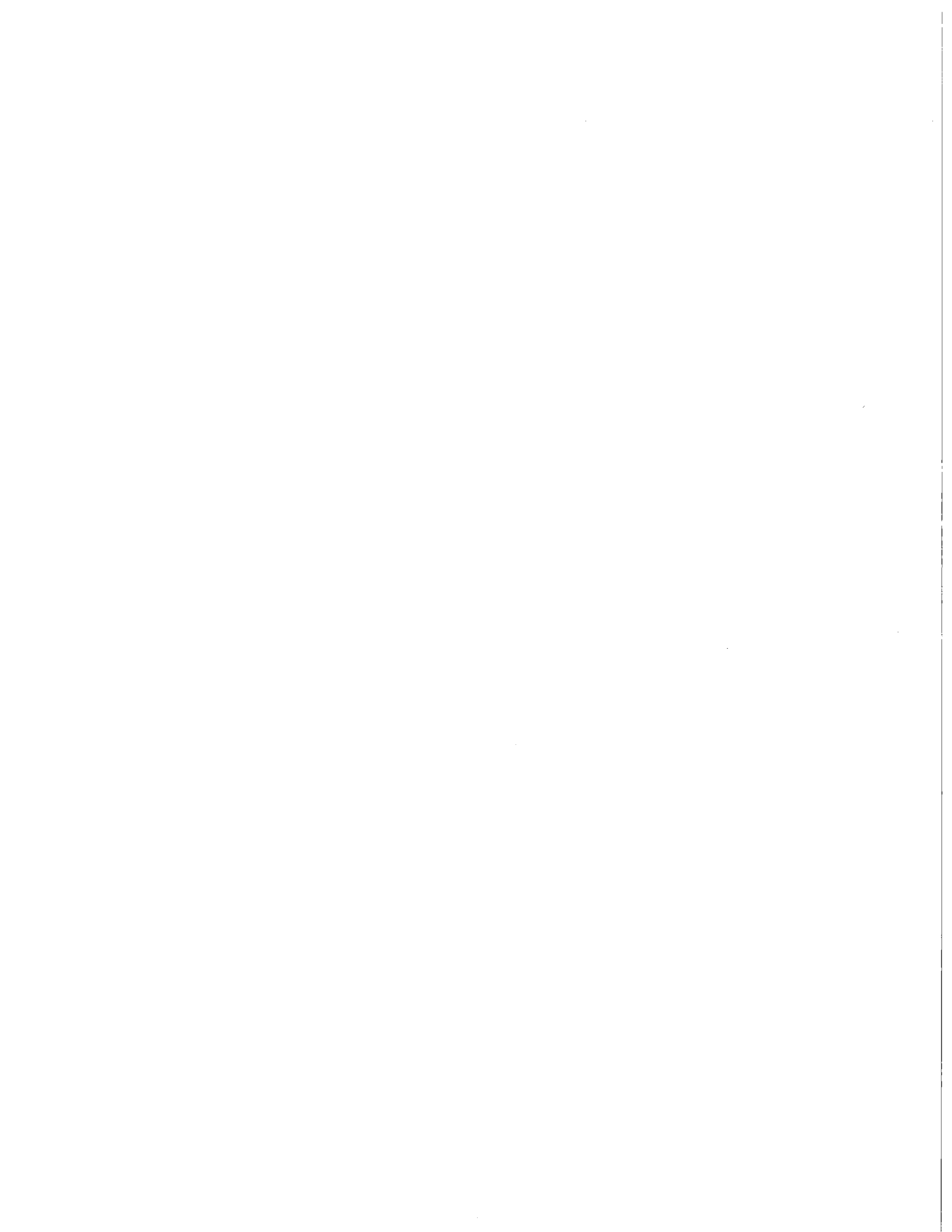

## I. BACKGROUND AND JUSTIFICATION

Despite recent major technological innovations and the great efforts that have been undertaken to disseminate them to the general population, infant and childhood mortality rates remain very high in most countries of the world (Behm, 1985; Rutstein, 1983). One of the strategies, which is commonly advocated for the prevention of childhood deaths, is the reduction of fertility levels through family planning.

Conditions of high fertility are associated with high levels of infant and child mortality. Results from ecological studies are in agreement with cross-sectional studies in this respect. High parity, old age, and short interpregnancy intervals have been long thought to be causally associated with increased chances of mortality in the perinatal and childhood periods (Mier y Terán, 1987; Omran and Standley, 1981; Puffer and Serrano, 1975; Winikoff, 1983).

Major expectations have been raised regarding the beneficial effects that changes in family formation patterns can exert on the perinatal health of the population in conditions of declining fertility. Most of the expectations stem from results of cross-sectional studies showing strong associations between birth spacing, maternal age, parity, and perinatal survival (Baird and Thompson, 1969, Becker and Hiltabidle, 1981). Only in recent years have analyses been undertaken in which birth order, age of the mother, and child spacing were simultaneously controlled for. Outstanding among them is the large comparative analysis of information from the World Fertility Surveys of 34 countries by Hobcraft, McDonald, and Rutstein (Hobcraft et al., 1985).

Results from longitudinal analyses, in which potential confounding variables were controlled for, suggest that age, parity, and birth intervals are much less significant determinants of perinatal mortality than previously thought (Geronimus, 1986; McCormick, Shapiro, and Starfield, 1984; Shah and Abbey, 1971). In addition, the effects of these variables are specific to the different components of perinatal mortality.

A recent review of the available scientific information (Bobadilla, 1987) concludes that:

Childbearing under 20 years of age is not causally associated with perinatal mortality, except probably below the age of 16. Increasing maternal age is strongly associated with antepartum fetal deaths and congenital anomalies but not with intrapartum fetal or neonatal deaths. Increasing maternal parity is related with intrapartum fetal deaths, but not with the other components of perinatal mortality. Sibship size is strongly associated with the perinatal mortality rate, however, there is no information on the probable differential effect on its components. Previous birth intervals smaller than 24 months are moderately associated with neonatal deaths.

The proportion of low birth weight babies is associated with rapid childbearing among teenagers and with first births among women 30 years old and above. Perinatal mortality and low birth weight are only moderately associated with high parities and older maternal ages, particularly if compared with the associations found between these variables and postneonatal mortality. This fact strongly suggests that biological factors are not likely to be mediators in the causal link between family formation patterns and child health (Bobadilla, 1987). In the case of childhood mortality, a major breakthrough in our understanding of the issue has been provided by the recent work of Hobcraft (Hobcraft, 1987). The salient characteristics of his work are that for the first time, patterns of family formation are studied, instead of the distinct variables: age, parity, and birth spacing. In addition, information from the World Fertility Survey in 18 countries was used, thereby increasing the external validity of the results.

Among Hobcraft's findings, the following are particularly relevant: a) heightened risk of dying during childhood for births to teenage mothers, in particular, if the births are of an order greater than one and poorly spaced; b) poorly-spaced births to 20-34 year old mothers experience excess risks, which rise rapidly with increasing reproductive pace; and c) considerable and systematic intercountry variability. This latter finding indicates that confounding factors must be involved in the relationship between bio-demographic variables and child mortality.

## II. PRIMARY GOALS AND SPECIFIC OBJECTIVES

The goal of this project is to determine the effects of variations in the family formation patterns on the rates of late fetal, neonatal, postneonatal, and child mortality. The specific objectives are: a) to evaluate the quality of information on mortality during childhood of the National Fertility and Health Survey, 1987 (ENFES); b) to describe the patterns of family formation, based on data on maternal age and parity and birth spacing, abstracted from the pregnancy histories; c) to estimate the rates of late fetal, neonatal, postneonatal, and childhood mortality and to establish the interrelationships with the patterns of family formation; and d) to investigate the relationship between family formation patterns and mortality in childhood, after controlling for other confounding factors.

## III. GENERAL METHODOLOGY

### Sources of Information

#### The National Fertility and Health Survey (ENFES, 1987)

The ENFES survey was conducted by the General Directorate of Family Planning of the Ministry of Health during the months of February to August of 1987. The general objective was to provide information for the analysis of the reproductive behavior of the Mexican population within a demographic and health context. The observation units were all of the households found in non-institutional dwellings, as well as all women of fertile age (15-49 years of age), who were living in the selected households at the time of the survey.

According to the sampling scheme, information can be generated for nine geopolitical regions, as well as for the three largest metropolitan areas of the country and for the population resident in communities of less than 2,500 inhabitants, of 2,500-19,999 inhabitants, and of 20,000 or more inhabitants. The sample is not self-weighted, that is, the probability of being selected differs for groups of individuals. The weight by which each record has to be multiplied is included in the data base and applied accordingly.

A full description of the methodology of the ENFES survey as well as the first findings can be found in the proceedings of three meetings on the ENFES held in February, September, and October, 1988 (SSA, 1988a, 1988b, and 1988c).

#### Vital Statistics

The following information was sought from the vital statistics for the Republic of Mexico and for the Federal District (Distrito Federal), for every year from 1970 to 1987: a) live births by sex; b) fetal deaths by detailed gestational age, in months; c) infant deaths by sex and detailed age at death, in months; and d) preschool deaths by sex and detailed age at death, in years.

The information collected was not complete, due to administrative problems related to the move of the National Institute of Statistics, Geography and Informatics (INEGI) headquarters from the capital to the state of Aguascalientes in recent years. Data on deaths were available only up to 1984 or 1985. Information on fetal deaths occurring in the Federal District during the period 1970-1973 and on infant deaths by detailed age at death for the years 1975, 1976, and 1979-1983, both for the country as a whole and for the Federal District, was not available; the same is true for information on preschool deaths for the two regions for the period 1975-1978.

The infant mortality rates obtained from the official data for the country as a whole are known to underestimate the actual situation. On the other hand, the corresponding rates for the Federal District are thought to faithfully represent reality and are lower than the true national average rate, due to the higher socioeconomic development of the Federal District's population in comparison to that of other states.

## Study Population

For the purposes of this study, the original ENFES data base was transformed, so that the records no longer represent the interviewed women but represent instead the outcomes of their pregnancies, that is to say, abortions, fetal deaths, and live births. Only those variables relevant to the present study were retained in order to increase the speed in data processing. All live births and fetal deaths from mothers, who had one or more multiple births, were eliminated from the file (226 women or 2.4 percent of the total). The new data base, which was utilized as such for the evaluation of the quality of the information on mortality, resulted in 23,466 records, representing the live birth and non-live birth events between 1947 and 1987 and distributed as shown in Figure 1.

Abortions were recoded as late fetal deaths, if the loss occurred after the fifth month of gestation (59 cases formerly recorded as abortions); and an event reported as a stillbirth was reclassified as a neonatal death, if the mother said it gave signs of life (40 cases). The resulting distribution is as follows: 1,920 abortions (8.2 percent of the total events) and 21,546 births, of which 340 (1.6 percent) are late fetal deaths and 21,206 (98.4 percent) live births. Of the latter, 19,357 (91.3 percent) were still alive at the time of the survey and 1,849 (8.7 percent) had died at some time between birth and the day of the interview.

The deaths occurring among the live births are distributed as 676 neonatal deaths (36.6 percent of total deaths) and 590 postneonatal deaths (31.9 percent), which result in 1,266 infant deaths (68.5 percent) and 357 deaths in the preschool years (19.3 percent). The definitions of the age periods used to classify deaths in childhood can be found in the Appendix. This, in turn, means that of the 1,623 deaths occurring during childhood, that is, the first five years of life, which represent 87.8 percent of the total deaths in the sample studied, 41.7 percent correspond to mortality in the first month of life, 36.4 percent to mortality in the remainder of the first year, and 22.0 percent to deaths in the 1-4 year age period.

From this data base, a second data base was derived for the study of the relationship between family formation patterns and child survival. It consisted of all live births whose date of birth was between 12 and 179 months before the interview date. The preschool mortality rates, as well as those for the childhood period, were calculated on the subsample of children, whose date of birth was comprised between 60 and 179 months before the date of the interview, in order to allow for full exposure time.

## Analysis

Because of the characteristics of the sample, the individual cases were weighted by the factor included in the ENFES data base prior to any calculation, including the mortality rates. Rates based on a denominator smaller than 500 (sample) are presented in brackets in all tables and figures. It is assumed that in such cases the rates are seriously affected by random errors.

Originally, we intended to relate the family formation patterns to the weight of the babies at birth. This idea, however, had to be abandoned on two grounds: a) birth weight was asked only for the subsample consisting of the live births occurring after 1982; and b) birth weight was reported by the mothers for only 65.4 percent of this subsample.

## Quality of Information on Mortality

The evaluation of the quality of information on mortality consisted in the following two steps: a) The distributions of the late fetal, neonatal, postneonatal, infant, preschool, and childhood mortality rates by the following list of variables were calculated: geographical regions, size of community where the mother lived at the time of the survey, age and parity of the mother at the time of the index birth, and age and education of the mother at the time of the interview. These distributions were analyzed globally and by periods of time. Each one of the distributions was expected to follow a specific known pattern of association; b) the obtained rates and trends were compared with those from the other sources of information, such as the vital statistics and data from the Mexican Fertility Survey of 1976-1977.

FIGURE 1. SAMPLE DISTRIBUTION OF VITAL EVENTS AROUND  
PREGNANCY AND CHILDHOOD: 1947-1987  
(ENFES 1987)

N= 23,466 ABORTIONS 1920	BIRTHS		21,546
	LATE FETAL DEATHS 340 STILLBIRTHS (REPORTED) (1) 281 STILLBIRTHS REPORTED AS ABORTIONS 59	LIVE BIRTHS	21,206
	LIVE BIRTHS (REPORTED)	21,166	
	LIVE BIRTHS REPORTED AS STILLBIRTHS	40	
	D E A T H S (3)		LIVING PERSONS (3) 19,357
	CHILDHOOD DEATHS 1,623	LATER DEATHS 226	
	INFANT DEATHS 1,265	PRESCHOOL DEATHS 357	
	NEONATAL DEATHS 676	POST- NEONATAL DEATHS 590	

1. The mother reported a gestational age of 6 or more months at the time of delivery
2. By the mother: these babies gave signs of life after birth
3. At the time of the survey

FIGURE 2. VARIABLES USED TO CLASSIFY NEWBORN BABIES BY FAMILY FORMATION PATTERNS AT THE TIME OF BIRTH<sup>1</sup>

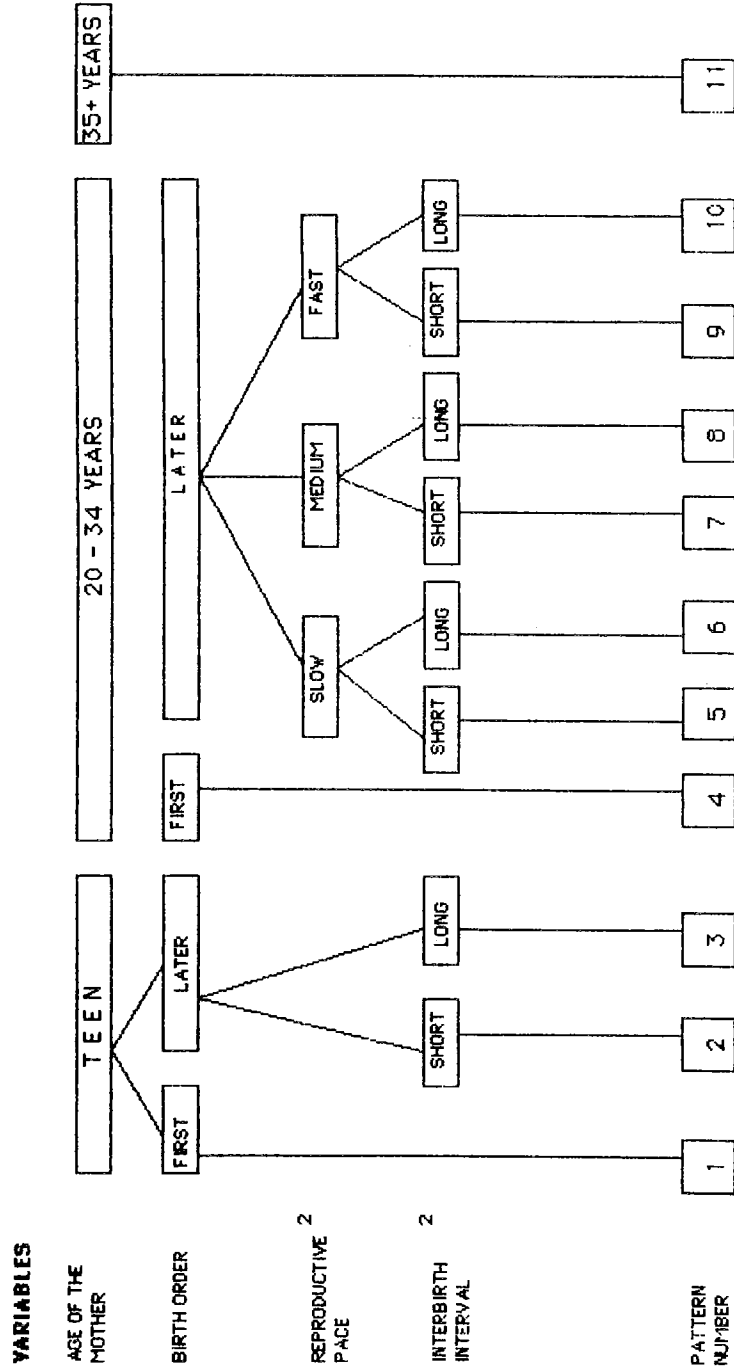

1. Drawn and adapted from the classification proposed by Hobcraft (1988)

2. See Appendix 1 for definition of pace and length of interval

## Relationship between Family Formation Patterns and Mortality

For this part of the analysis, the following steps were followed: a) The births were characterized in terms of their year of occurrence, as well as the age, reproductive pace, birth spacing, and parity of the mothers. b) Second, the family formation patterns were constructed, based on those created by Hobcraft (1987), as explained below. They were studied in relation to time and to the education and size of the community of residence of the mother at the time of the survey. The patterns of family formation were defined by means of a classification system, which takes into account four variables, as shown in Figure 2.

Births were divided into three groups, according to age of the mother (teen, 20-34 years, and 35 years and above). The first two age groups were each subdivided into two subgroups, according to birth order (first and subsequent births). The older women were not disaggregated further. Later births to teenagers were subdivided into two final groups, according to birth spacing (well spaced or with a long birth interval with the previous sibling and poorly spaced or with a short interval). Births to mothers aged 20-34 years, of an order higher than one were subdivided into six groups, according to (1) their mother's reproductive pace, which depends on her parity at the time of the index birth (slow, medium, and fast reproducers: see Appendix A for definitions) and (2) the length of the time interval from the previous birth (poorly spaced and well spaced). One additional pattern was added to the original 10 considered by Hobcraft. In it were grouped all the births to women 35 years of age and older. The results are described as the proportion of births, which fall in any of the eleven resulting groups. c) Next, the time-specific mortality rates were cross-tabulated with a number of biological and social variables in order to analyze the determinants of child mortality. d) In order to determine the relationship between the family formation patterns and child mortality, the late fetal, neonatal, postneonatal, infant, and childhood mortality rates were estimated for each of the 11 family formation categories (bivariate associations). e) Multivariate analysis of the effect of the family formation patterns on childhood mortality was performed by means of logistic regressions for each of the following mortality periods: infant, neonatal, postneonatal, and childhood. The analysis of the neonatal and postneonatal periods must be interpreted with caution.

In the logistic models, the odds of mortality were evaluated for each family formation pattern, after controlling for the effects of confounding variables, such as educational level and size of the community of residence of the mother. Odds are defined as the frequency (or probability) of one category of a variable as compared to the frequency (or probability) of another. Odds are typically expressed as ratios. In this way, the estimated logistic models are of the following form:

$$\text{Log (odds of mortality)} = u + u_{1(i)} + u_{2(j)} + u_{3(k)}$$

where  $u_{1(i)}$ ,  $i = 1, 2, \dots, 10$  represents the effect of the  $i$ -th level of the variable, family formation pattern, on the log-odds of mortality (known as the logit of mortality) controlled by the effects of the variables  $u_2$  and  $u_3$  (maternal education and community size, for example). The subindices  $j$  and  $k$  represent different levels of the two variables, respectively. As the right-hand side of the above equation is formed by categorical variables, the model is known as a logit model.

Some restrictions are imposed on the parameters of a logit model. We shall be using an effect-coding representation, rather than the more familiar dummy-variable coding. For the effect coding, the restrictions are that the sum of the effects of all of the categories of any variable (the  $u$  terms) are equal to 0. In the dummy-variable coding, the effect of one category is scored as zero. The translation between the two codings is straightforward (see De Alba, 1988). The SPSS-X package, which was utilized to fit the logit models to the data, works with an effect-coding representation. In it, the estimated coefficients can be interpreted as deviations from an "average" across categories. The "average" in this case is the geometric mean of the effects of the categories of a given variable. This average is taken as the reference point, because of the use of effect coding in the logit equation, which is in a logarithmic scale. The reference point for the coefficients of effect-coded variables consists of the arithmetic average of effects across the categories of the variable.

The above logit equation may be rewritten in a more understandable fashion as follows:

$$\text{Log (odds of mortality)} = \lambda + \sum_i \lambda_{1(i)} X_{1i} + \sum_j \lambda_{2j} X_{2j} + \sum_k \lambda_{3(k)} X_{3k}$$

where  $X_{1i}$  is the  $i$ th level of the variable family formation pattern,  $X_{2j}$  the  $j$ th level of the variable mother's education, and  $X_{3k}$  the  $k$ th level of the variable community size. The parameters are estimated from the data. They can be interpreted as odds relative to the geometric average of effects of the categories of one variable.

#### IV. RESULTS AND DISCUSSION

##### Quality of the Data

##### Late Fetal Mortality

The ENFES data on late fetal death appear to be more complete than those for the Mexican Fertility Survey (EMF, 1976) because the EMF mortality estimates for this period are always lower than those based on the vital registry, and they do not show the expected inverse relationships with the socioeconomic variables considered, whereas the ENFES data do (Bobadilla, 1985). The difference in quality between the ENFES and the EMF data could be due to the correction performed to the ENFES data, by which losses erroneously reported as abortions were recodified as late fetal deaths. The ENFES data are, however, underestimated for the 1972-1976 period (Table 1), so that only late fetal deaths in the 1977-1986 period will be considered for further analysis. In this analysis, any mortality rate estimate lower than the corresponding national or Federal District (D.F.) ones derived from the vital statistics, is considered to be based on an incomplete reporting of deaths.

##### Childhood Deaths

Data on infant deaths appear to be complete in the three quinquennia: 1972-1976, 1977-1981, and 1982-1986 (Table 2). It was encouraging to find the expected inverse associations with social variables and a declining trend in time. However, if separate analyses for the neonatal and postneonatal groups are performed, care should be taken in the interpretation of the results, since a transference of deaths from the latter to the former group is likely to have taken place. Finally, for deaths in the first year of life, it is suggested that no differentiation be made by sex, as the expected trend was not found.

Data on preschool deaths should not be used for the analysis of differentials, because of the small numbers. Neither should they be used in stratified and multivariate analyses. It is therefore suggested that deaths in the group aged 0 to 5, that is, childhood deaths, be considered instead. Table 3 shows the comparison with the vital statistics-based rates of the ENFES preschool mortality rates. The ENFES preschool mortality rates are slightly lower than the vital statistics for Mexico and higher than those for the D. F. in each of the two time periods considered: 1972-1976 and 1977-1981. The childhood mortality rates are higher than both the vital statistics for Mexico (15.9 percent higher in the 1972-1976 period and 33.3 percent higher for the 1977-1981 period) and those for the D.F. (16.7 percent and 69.0 percent higher for the 1972-1976 and 1977-1981 periods, respectively).

In conclusion, the ENFES data on mortality have been found to be of good quality, in general. This is the first time in Mexico, and probably elsewhere, that data from late fetal deaths derived from household interviews (pregnancy histories) have been used to study the determinants of perinatal health. The minor problems found in this paper for the ENFES data on infant mortality are similar to those reported for the EMF (1976). It is difficult to compare these results with those of other countries, since most of the analyses of information from surveys in other countries have not evaluated (or not reported) the data on mortality from pregnancy histories.

The probable transfer of deaths from the postneonatal to the neonatal period may be common to other demographic surveys where pregnancy histories are recalled, because of the way age at death is asked. In effect, mothers may report the first month as the age at death when, in fact, their child may have died 5, 6, or even 7 weeks after birth.



The truncation of the sample of births is also a problem, described by most of the researchers who have worked with cross-sectional demographic surveys. In relation to the family formation patterns (FFP), the effect of truncation becomes very important when evaluating the survival of births to women aged 35 years or above. Because of the sample truncation, the proportion of these births in relation to total births is underestimated in demographic surveys, as compared to the actual proportion. This has a direct impact on the estimates of the population etiologic fraction of infant mortality for each family formation pattern. The etiologic fraction of births from mothers aged 35 and above is underestimated.

One inherent bias of retrospective observational studies of infant mortality, based on data recalled by the mother, is that produced by the omission of births to women, who died during the observation period and did not enter the sample. For the overall level of mortality, this represents only a minor problem, since the proportion of maternal as compared to infant deaths is only 10 percent, and not all the births of women who died necessarily died in childhood. At most, it will underestimate the rate of infant or childhood mortality by 5 percent. However, it is well established that the FFP are strongly related to maternal mortality, particularly in the cases of short intervals and high parity (Winikoff, 1983). In turn, children born to mothers, who died in labor or the puerperium, have extremely high mortality, between 30 and 50 percent.

## **The Patterns of Family Formation in Mexico**

### Distribution and Time Trends

In a strict sense, the construct of family formation should include not only the patterns of reproduction, but also other variables concerning the timing and types of marriages and the presence of other members of the family (next of kins). Perhaps a better way of referring to Hobcraft's groups would be "reproductive patterns," so that the term "family formation pattern" can be reserved for the broader construct.

This is the first time that the FFP are described for Mexican live births. Shown in Table 4 is the distribution of the births occurring between 1 and 14 completed years prior to the survey across the 11 family formation patterns, globally and by five-year periods of time. For the entire sample, later births to teenage mothers are poorly represented, whether they are well spaced (1.8 percent) or poorly spaced (4.2 percent). This is to be expected because of the small exposure time and because the bulk of births is concentrated in the age group 20-34 (73.8 percent). Among these latter births, the great majority are subsequent births (82.3 percent). From every 10 subsequent births to women 20-34 years old, almost five occur after a short interbirth interval. The poorly-spaced births altogether represent 31.8 percent of the total sample of births.

Poorly-spaced births to mothers 20-34 years old are uniformly distributed among the three reproductive pace categories (slow: 9.7 percent; medium: 8.8 percent; and fast: 9.1 percent). In contrast, among the well-spaced births and for the same age-of-the-mother range, the proportion of births associated with a slow reproductive pace almost doubles that of births associated with a fast pace (slow: 14.0 percent; medium: 11.4 percent; and fast: 7.7 percent). With interbirth intervals of a magnitude of two or more years, it is logical to expect a greater percentage of women with slow or medium than with fast reproductive paces. On the other hand, small interbirth intervals are compatible with either slow, medium, or fast paces. In this case, the age at which reproductive life is initiated is the determining factor. To be noted as well is the relatively high proportion of births to women over age 35 (9.8 percent).

When looking at the trends over time of this distribution, some interesting patterns can be observed. The patterns representing well-spaced births to 20-34 year old mothers with slow and medium reproductive paces become more predominant in recent times (slow: from 10.5 percent in 1972-1976 to 18.2 percent in 1982-1986; medium: from 10.5 percent in 1972-1976 to 13.1 percent in 1982-1986). These patterns are associated with two of the four lowest mortality rates described in Hobcraft's analyses of 18 countries (Hobcraft, 1987). On the other hand, patterns associated with the highest mortality levels (according to Hobcraft, 1987), have become less important over the years from 1972-1976 to 1982-1986: 20-34/ later poorly-spaced/ medium pace: 10.5 to 7.4 percent; 20-34/ later poorly-spaced/ fast pace: 12.4 to 6.7 percent; and teen/ later poorly-spaced: 4.9 to 3.0 percent.

## Comparison with Family Formation Patterns of Other Latin American Countries

Table 5 shows the results found by Hobcraft (1987) for four Latin American countries: Colombia, Costa Rica, Panama, and Peru. The ENFES data, restricted to births of women less than 35 years old, were added for comparison's sake. These countries show a similar proportion of teenage to total births, ranging from 15.7 percent to 19.3 percent (Mexico: 18.1 percent). The proportion of first births of all teenage births is again similar and varies from 56.9 to 63.5, with Mexico showing the highest figure. Among women aged 20-34, later births are more or less evenly distributed among the slow, medium, and fast reproductive pace categories. Although not shown in tabular form, there are slight variations among countries, with Colombia and Costa Rica having the highest proportion of births in the fast pace group (39.0 and 39.7 percent, respectively) and Mexico and Peru the lowest one (27.7 and 31.7 percent, respectively). Mexico also has the lowest proportion of poorly-spaced births (45.5 percent) of all the subsequent births to 20-34 year old mothers. The figures for the other countries are: Colombia and Costa Rica: 56 percent, Panama: 48 percent, and Peru: 46 percent. Finally, Mexico also shows the lowest percentage for the group with poorest fertility control: poorly-spaced births to 20-34 year old women with a fast reproductive pace (10.1 percent). Colombia and Costa Rica have the highest figures (17.2 and 18.7 percent, respectively), and Panama and Peru are intermediate (12.6 and 12.7 percent, respectively). It is to be remembered that the Mexican data refer to the period 1972-1986, whereas the data from the other countries refer to periods comprised between 1961 and 1975.

## Mother's Education

Table 6 shows the distribution of births across different levels of education of the mother (at the time of the survey) for each of the eleven family formation categories. The greatest percentage of births to women with no schooling at all belong to the following categories: 20-34/ later well-spaced with medium pace (13.2 percent) and fast (13.0 percent) reproductive pace; 20-34/ later poorly-spaced with a fast reproductive pace (14.0 percent) and 35 and above (18.1 percent). The highest educational category (7 and more years of schooling) is represented mainly by first births to 20-34 year old women (28.5 percent), or later births to 20-34 year old women with a slow reproductive pace, either well spaced (24.1 percent) or poorly spaced (14.5 percent), and first births to teenage women (13.7 percent).

When looking at the average years of schooling, it can be observed that the groups formed by later births to fast reproducers, whether well or poorly spaced, (2.5 and 2.8 years, respectively), and by births to older women (2.6 years), both average less than 3 years of education. Later births to teenagers (3.1 for well spaced and 3.7 for poorly spaced) are also below the average for the total population (4.2 years). On the other hand, the groups with the highest educational level correspond to the first births to 20-34 year old women (6.6 years) and to teenagers (5.0 years), as well as to later, well-spaced births to 20-34 year olds with a slow reproductive pace (5.9 years). Some of these results are consistent with the assumption of a change in the family formation patterns associated with a reduction of fertility. A lower level of fertility is expected among better educated women. Indeed, the proportion of well-spaced births to women aged 20-34 with a slow reproductive pace is greater in the highest educational group (24.1 percent) than in other educational groups. They also have the second highest average number of years of schooling (5.9). On the other hand, the proportion of later poorly-spaced births to women of the same age group with a fast reproductive pace, a pattern probably associated with poor control of fertility, is greater in the lowest educational groups (0 years: 14.0 percent; 1-3 years: 12.2 percent). The average schooling for this group is 2.8 years, far below the average. It is to be noted that the proportion of births to women age 35 years and above decreases as the educational level of the mother increases (0 years: 18.1 percent; 1-3 years: 10.8 percent; 4-6 years: 6.7 percent; and 7 and more years: 3.7 percent).

## Community Size

Table 7 shows the distribution of births, according to the size of the population of the community of residence of the mother at the time of the survey. The different family formation groups have a pattern of behavior analogous to that for the education of the mother. This is not surprising in view of the high correlation between the variables: rural communities (i.e., communities with a small population size) have a lower average educational level than urban ones (population size of 20,000+). Rural communities are thus known to have less fertility control than urban ones. Later well-spaced births to teenage mothers, later well-spaced births to 20-34 year old mothers with medium and fast reproductive paces, poorly-spaced births to mothers of the same age

group with a fast reproductive pace, and births to older women show a decline with increasing population size. On the other hand, first births and later, either well- or poorly-spaced births to 20-34 year old women with a slow reproductive pace show the reverse trend: Their importance becomes greater in urban areas.

In conclusion, important changes in time were described in the distribution of births across the family formation patterns. In general, births shifted from older to younger ages of the mothers. In addition, births to women aged 20-34 years shifted from short to long birth intervals. That the FFP are associated with the overall level of fertility is clearly demonstrated by the changes seen over time. In addition, the strong correlation between education of the mother with the FFP provides further evidence of the aforementioned association. In general, the better the socioeconomic status (as measured by education and community size), the lower the fertility, the younger the age of the mothers, and the longer the birth intervals.

Although the typology of family formation patterns used in this project splits the sample of births in too many (eleven) cells, it has many advantages. First, it leads to a surprisingly even distribution of births. Second, conceptually, the typology used is very robust. It was derived from previous research, in which each of the classification criteria was shown to be relevant for the survival of children under five years of age. The pace of reproduction constitutes an exception, since its effect on mortality had not been studied by the time Hobcraft's (1987) paper was published. The most important attribute of the typology is its strong capability for discriminating groups of births, according to their probability of dying in the childhood period, in societies with distinct levels of childhood mortality.

Nevertheless, there are some ways in which the present FFP could be refined for use in future research. For instance, the group of births to older women (35 years old and above) would be more informative if it were subdivided according to the length of the interval with the previous birth. In this way, the effects of age could be separated from those of poor spacing. This is particularly relevant for populations where there is a high proportion of births to women aged 35 and above. Similarly, in developed societies, where first births are common among women of this age group, the separation of first from later births is essential. In the ENFES sample, the proportion of births to women 35 years old and above is only 9.8 percent, so that a subdivision in three groups would lead to sample size problems. At the other extreme of the age continuum, a definition of the teen births as those occurring to women aged less than 17 years of age would yield better estimates of the age effect on mortality. Indeed, Hobcraft (1987) shows that the chances of dying of births to mothers aged 17, 18, and 19 years are similar to those of births to women 20-24 years old.

### **The Determinants of Child Mortality**

In this section, general trends of mortality levels during childhood and bivariate associations of certain social and biological factors with mortality rates are presented. The intention is not to generate new insights on the determinants of childhood mortality. Rather, the results of this analysis will facilitate the interpretation of the relationships between family formation patterns and mortality. In effect, because of the known multifactorial determination of childhood mortality, the effect of possible confounding factors, other than those involved in the formation of the patterns, needs to be known and described.

#### Levels and Trends of Infant Mortality

The ENFES data, for the first time, permit the description of late fetal mortality at the national level. Late fetal mortality was 22 per 1,000 births for the period 1977-1981 and 16 for 1982-1986. This represents a reduction of approximately 27 percent. The perinatal mortality rate was calculated to be 50.4 for the years 1977-1981 and 40.3 for the 1982-1986 time period.

Table 8 shows the high degree of correspondence existing between the ENFES and the Mexican Fertility Survey (EMF) mortality estimates. The neonatal mortality rates show a difference of 12 percent between the two sources of information. This difference is minor, however, from a public health perspective. The similarity of the infant mortality rates is remarkable, especially if one considers that the composition of the sample in terms of the age of the mothers was not quite the same in the two surveys, in the time period considered, because the truncation effect for the ENFES data is greater for those years than that of the EMF data.

The figures obtained from the ENFES on infant mortality are the best national estimates for the 1980s. The level observed for the years 1982-1986, of 43 deaths per 1,000 live births, is high considering the availability of resources and the coverage of health care in Mexico. It is interesting to note, however, that the rate of decline of the infant mortality rate in Mexico is steeper in the 15 years before the survey than in the previous 15 to 20 years (Figure 3). The steepest decline was seen in the period 1982-1986. It is a paradox that the economic crisis started in Mexico in this same period.

This paper shows that the underestimation of infant deaths has increased during the past 15 years, reaching 40 percent in 1982-1986. This is due almost entirely to the underregistration of neonatal deaths, since the postneonatal mortality estimates from vital statistics are similar to those of the ENFES in 1982-1986 (Table 2). The underestimation of the neonatal mortality rate is 53 percent. In other words, from every 10 deaths only 5 are registered, according to the data obtained from the ENFES. A similar level of underregistration is found for late fetal mortality in the same period (46.5 percent).

Notwithstanding the important decline in infant mortality over the years, it is to be noted that the reduction in the rates was very unequal in different regions of the country. Infant mortality rates were calculated for two contrasting geopolitical regions: a northern region, known a priori to be one of the most thriving in the country and a southern, more backward one. Figure 4 shows that the south-north difference (relative risk) changed from 1.8 for the period 1962-1971 to 5.0 for 1982-1986.

A similar pattern can be observed in Figure 5, where infant mortality rates are plotted in time for communities with different population sizes. The difference in mortality between rural communities (<2,500 inhabitants) and metropolitan areas increases for the same time periods, from 1.8 to 5.1. The difference in infant mortality rates between groups in the extreme of the educational level spectrum increases over time as well (Figure 6). During the period 1962-1971, the excess infant mortality of children born to mothers with no schooling, as compared to those born to mothers with 7 or more years of schooling, was 2.2. This figure increased to 4.3 for 1982-1986. This widening of the gap in health indicators between socially different groups has been designated as epidemiologic polarization (Frenk et al., 1989).

### **Correlates of Child Mortality**

Table 9 shows the existing gradient between mother's education, measured as years of schooling, and the mortality rates during childhood. The relationship is well known even though the mechanisms through which education exerts its effect have not yet been satisfactorily elucidated. Other social variables, such as occupation and conditions of the home, have been associated with infant mortality in previous research. However, since these variables were measured for the time of the survey and they show a greater degree of variability in time as compared to education, we decided not to explore their correlation with child mortality.

#### Age of the Mother at Birth

The bivariate association between age of the mother at the time of the index birth and mortality during childhood shows that all the mortality rates studied, with the exception of that for the preschool period, are greater for the children born to mothers less than 20 years of age (Table 10). Practically no differences can be found between the values for the babies born to 20-34 year old mothers and to mothers aged 35 years and above, with the exception of late fetal mortality. The different behavior of the preschool death rates may be due to the instability of the rates, due, in turn, to low numbers.

#### Birth Order

During childhood, first-born babies have death rates, which are always lower than those for later births (Table 11). When later births are disaggregated by parity, the neonatal mortality rate can be observed to be lowest for birth order 2. In the case of infant mortality, the rate increases to an important degree from birth order 3, onwards. The typical J-shaped relationship is not apparent in these data.

FIGURE 3

### INFANT MORTALITY TRENDS MEXICO, 1951 - 1986

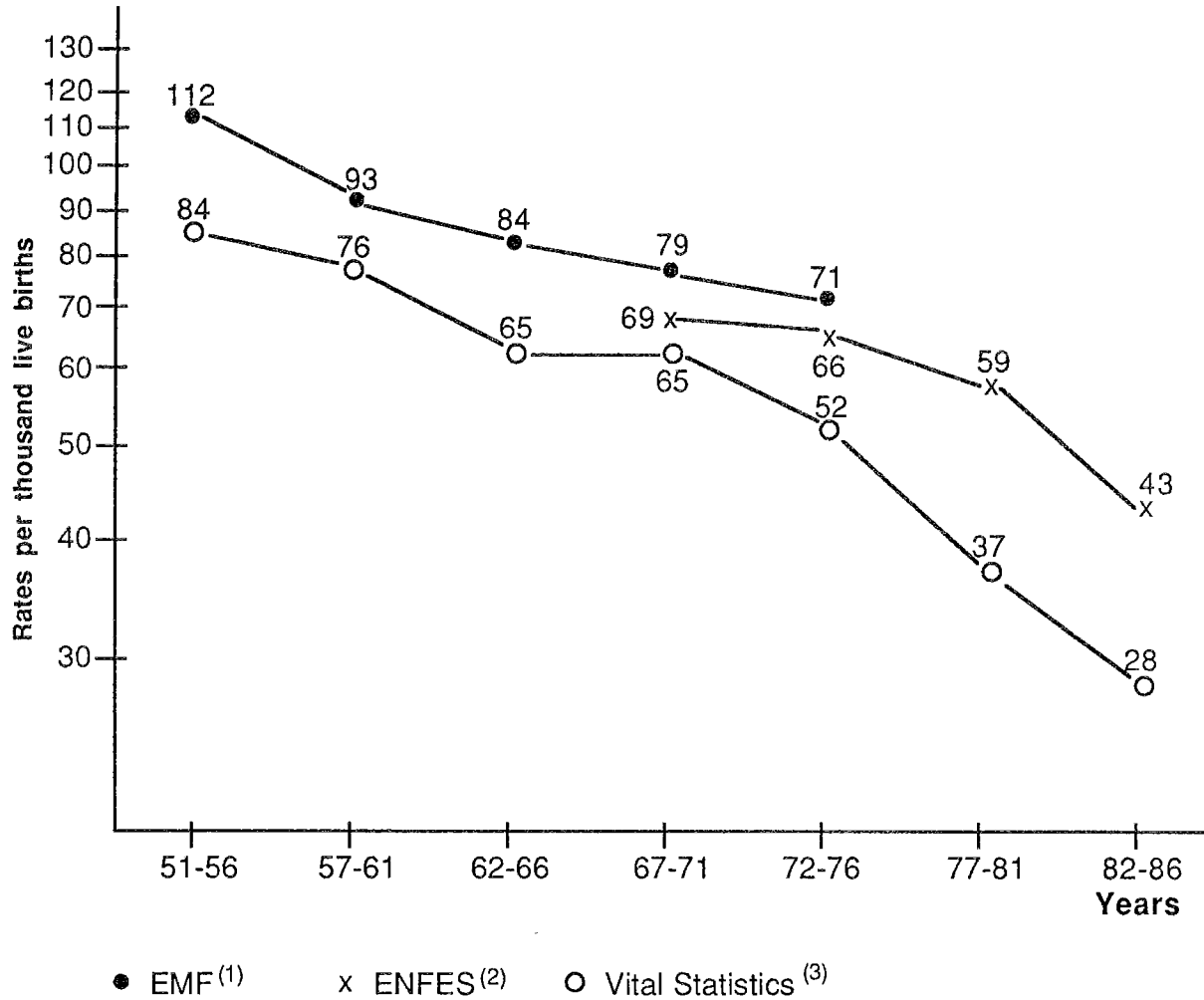

**Sources:** (1) Ordorica M., Potter J. (1981)  
(2) Ministry of Health (1989)  
(3) General Directorate of Statistics (1989)

FIGURE 4  
INFANT MORTALITY RATE TRENDS IN TWO  
GEOPOLITICAL REGIONS  
(ENFES 1987)

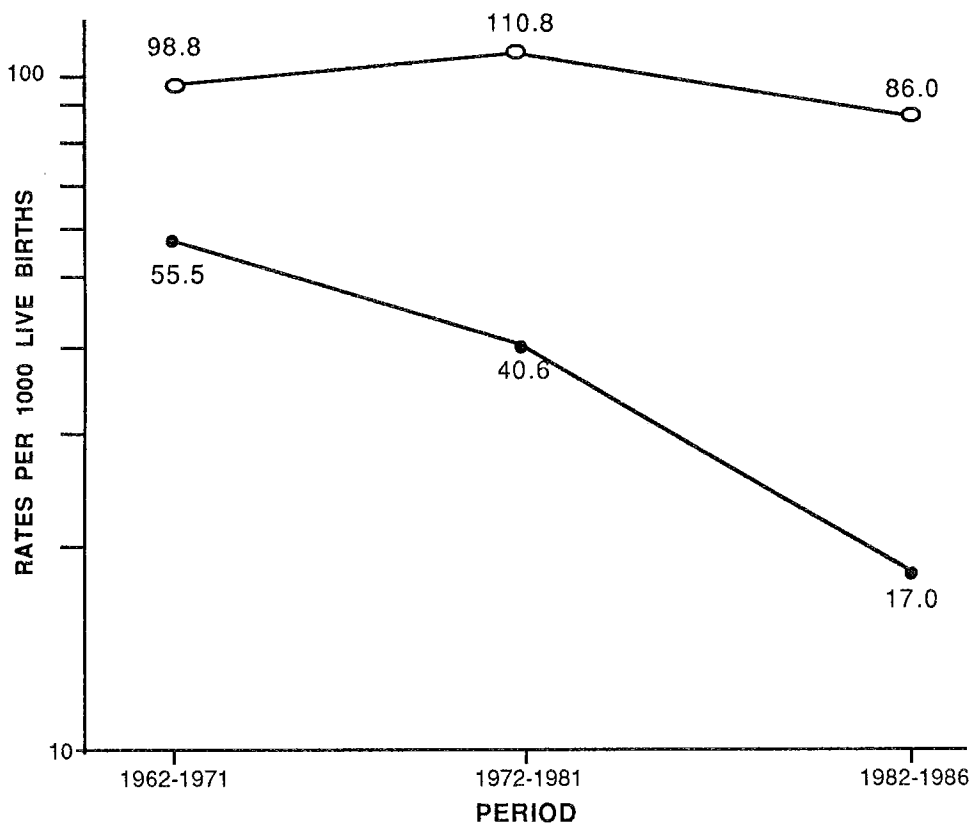

● NORTH

Includes the states of: Baja California, Baja California Sur, Sonora, Sinaloa, Nayarit.

○ SOUTH

Includes the states of: Tabasco, Yucatán, Campeche, Chiapas, Quintana Roo.

**FIGURE 5**  
**INFANT MORTALITY RATE TRENDS IN**  
**COMMUNITIES OF DIFFERENT**  
**POPULATION SIZE**  
**(ENFES 1987)**

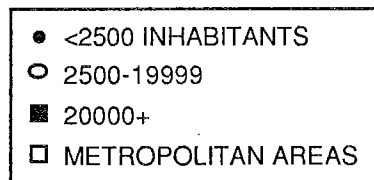
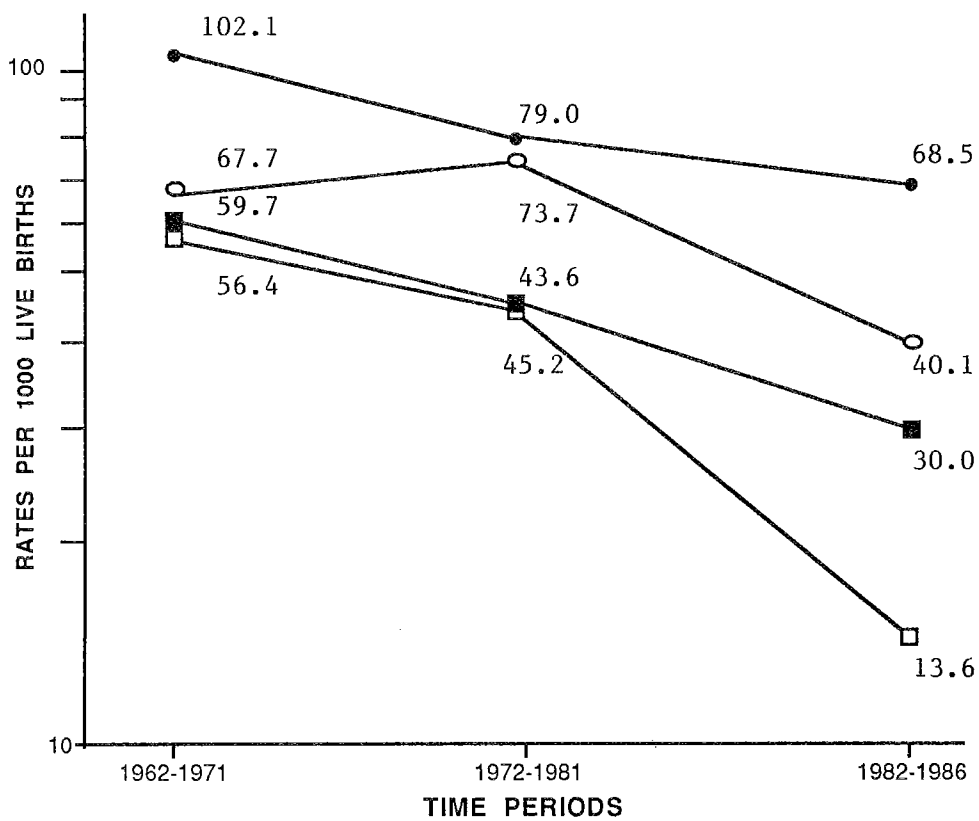

**FIGURE 6**  
**INFANT MORTALITY RATE TRENDS BY**  
**YEARS OF SCHOOLING OF THE MOTHER**  
**AT THE TIME OF THE SURVEY**  
**(ENFES 1987)**

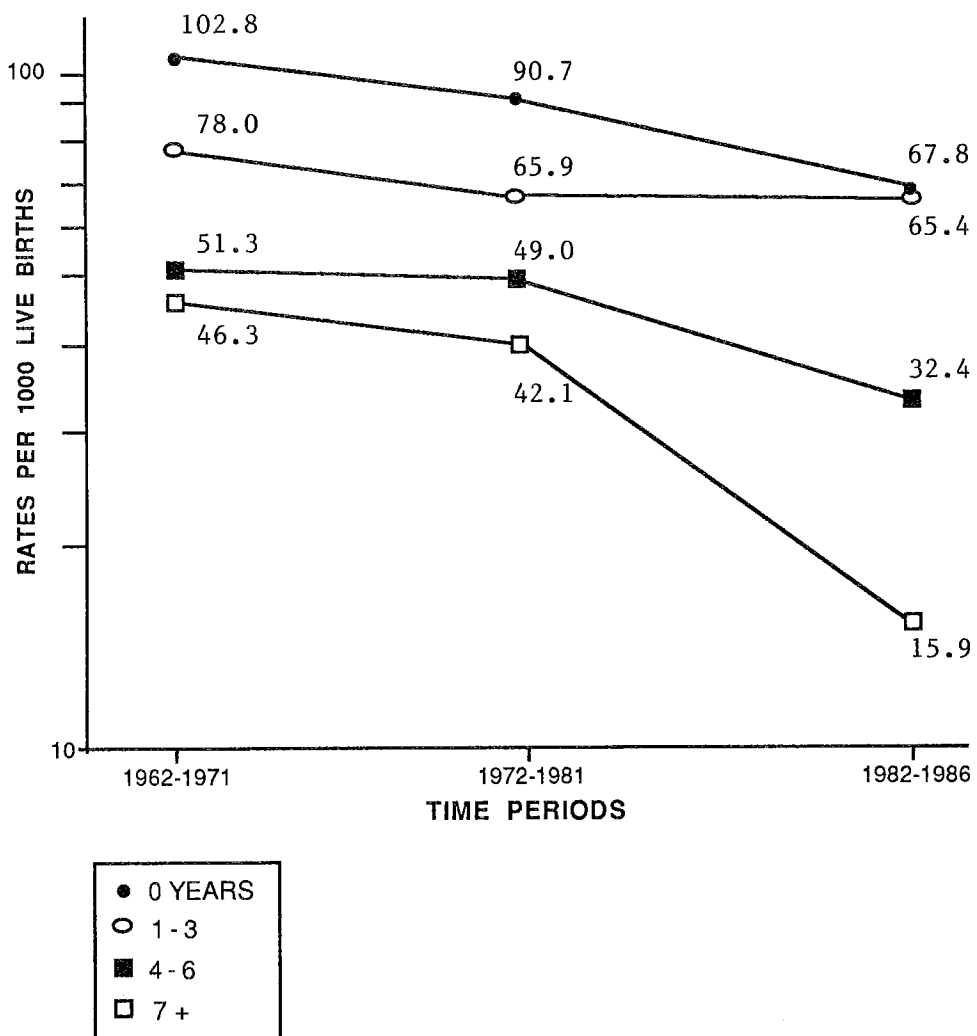



### Reproductive Pace

A close relationship was found between reproductive pace and all of the mortality rates (Table 12). The infant mortality rate is 2.2 times higher among babies born to women with a fast reproductive pace (84) than among babies born to slow reproducers (39).

### Interbirth Interval with a Previous Sibling

Table 13 shows the association between birth spacing (with the previous sibling) and mortality during childhood. As the interbirth interval becomes shorter, the probability of dying tends to increase. Births occurring after an interval of 6 months and less after the births of the previous sibling were excluded, since they represent, by definition, premature births. Children born in the period from 7 to 11 months after the birth of their sibling have an infant mortality rate 3.7 times higher than those born 3 to 5 years after the previous birth.

In summary, the known inverse relationships between socioeconomic variables and infant and child mortality are confirmed. A process of epidemiologic polarization was demonstrated by showing that the infant mortality rates of socially more privileged groups have decreased more rapidly in time. On the other hand, the strong relationship of the variables, defining the family formation patterns with mortality in childhood was highlighted. Birth order and age of the mother at birth show a relationship with mortality, which is different from that previously described.

All the relationships which have been analyzed are confounded by third variables which, if taken into account, may change the bivariate associations.

### **The Effects of Family Formation Patterns on Child Mortality Patterns: Crude Associations**

A few considerations on the stability of the mortality rates are in order before describing the results presented in Table 14. The main criterion utilized to judge the stability of the rates was the size of the denominator. A denominator of less than 500 is an indication that the rate is unstable. In certain cases, the size of the numerator was also taken into account. When its value was less than 50, and the denominator was borderline, the rates were also considered to be unstable.

The group formed by teenage mothers with more than one well-spaced birth included 236 births in the period from 1 to 14 completed years prior to the survey. This represents a mere 1.8 percent of the total births for the period and 11.6 percent of the births to teenage mothers. It is therefore not a group of great public health significance. Of these babies, only 10 died during their first year of life. In addition, 5 babies died during the preschool years, in the period between 5 and 15 years prior to the survey. The mortality rates calculated with these numbers should be disregarded.

The family formation pattern constituted by teenagers with subsequent poorly-spaced births is also a small group. However, its contribution to the total number of births is greater (540 births and 4.2 percent of the total). More importantly, it includes 26 percent of the total births to teenage women. Fifty-nine babies died during the first year of life and 58 during the first 5 years of life, in the corresponding target time periods (i.e., 1 to 15 and 5 to 15 years prior to the survey). The estimated mortality rates should be stable enough. For the neonatal, postneonatal, and preschool periods, however, the number of deaths is 26, 33, and 8, respectively. Thus, only the infant and childhood mortality rates are considered worth analyzing without any major problem of random variability.

Most cells corresponding to neonatal and postneonatal mortality are based on numerators with less than 50 deaths. These figures should be analyzed with caution. On the other hand, the total number of preschool deaths is 136. All family formation patterns but one have fewer than 18 deaths. Preschool mortality rates will, therefore, not be analyzed separately.

### Late Fetal Mortality Rates

Turning now to the results, it can be seen that the groups with the highest late fetal mortality rates are a) births to 20-34 year old women with a fast reproductive pace and poor spacing (36.3); b) older women of 35 and more years of age (29.6); and c) 20-34 year old women with medium reproductive pace and poor spacing (25.2). These groups do not necessarily correspond to those with the highest neonatal mortality or to those with overall high mortality rates. The group consisting of births to women aged 35 years old and above is a case in point: With the exception of the high late fetal mortality rate, the rates for the other target age groups are quite similar to the average rates for the entire population.

### Neonatal and Postneonatal Mortality Rates

It can be noted that neonatal and postneonatal rates differ within each family formation group. Neonatal mortality is basically determined by biological factors. Postneonatal mortality, on the other hand, although also biologically influenced, is determined overwhelmingly by the social environment of the child. The social determinants are largely responsible for the neonatal-postneonatal differential in mortality rates, characteristic of each group. The low number of deaths in each cell, together with the problem described before, of a possible transfer of postneonatal to neonatal deaths, prevents us from drawing any definite conclusions in the interpretation of these differences.

### Infant and Childhood Mortality Rates

These two indicators behave very similarly across the 11 family formation patterns: The highest rates are found among the later poorly-spaced births to teenage mothers (106.8 and 135.8 for infant and child mortality, respectively) and the poorly-spaced births to 20-34 year old mothers, with either a medium (68.1 and 88.3, respectively) or a fast (103.6 and 128.5, respectively) reproductive pace. In addition, a high childhood mortality rate is found among later well-spaced births to fast reproducing women of 20-34 years of age (91.8). The lowest rates, both in infancy and in childhood, can be observed in the 20-34 year old group of mothers among well-spaced births to slow reproducers (28.6 and 43.8, respectively), and among first births to mothers of the same age group (28.3 and 38.9, respectively).

### Births to Teenagers

Infant mortality rates of first births to teenagers are similar, and for the childhood period, even lower than the average rates for the study population (51.8 and 67.5, respectively) (Table 14). The late fetal death rate of either first births (20.6) or later poorly-spaced (20.1) babies born to teenage mothers are not higher than the average (19.0). Children born to teenagers have been found, generally, to experience considerably higher risks of dying before age 5 (Hobcraft, 1987). Contrary to Hobcraft's findings, the ENFES data show a heightened risk only for those births to teenage mothers that are poorly spaced (Table 15). Compared with the total number of births, the excess child mortality for this latter group is 80 percent. On the other hand, compared to the well-spaced births to 20-34 year old women with a medium reproductive pace (Hobcraft's reference group), excess mortality rises to 90 percent. When considering the mortality risks of this group of poorly-spaced births for other periods, the relative risk with respect to the total sample, changes from 1.1 for the late fetal, to 1.7 for the neonatal, and 2.4 for the postneonatal periods. With respect to first births of teenage mothers, the corresponding figures are 1.0, 1.8, and 2.3, respectively. When comparing teenage births among themselves, the effect of poor spacing on child mortality can be observed. The relative risk of dying before age 5 for poorly-spaced births, as compared to first births, is 2.0. These effects are probably due to social, economic, and environmental factors, which place the teenage mother at a disadvantage. A comparison between poorly-spaced and well-spaced births to teenage mothers is difficult, because of the reduced number of births in the latter group.

Adjusting by schooling and size of the community of residence of the mother does not change to a significant degree the magnitude of the relative risks, either in infancy or in childhood (Tables 16 and 17). This is true both for first births and for the later poorly-spaced ones. When education alone is introduced in the model as a control, the relative risks of first births increase slightly for infant and childhood mortality (30 percent and 40 percent increases, respectively). This means that there is probably a slight biological effect, which was

hidden by the relatively high educational level of the group: 5.0 years (vs. total births: 4.2 years).

### Births to Women Aged 20-34 Years

First births. As compared to the total sample of births, first births to 20-34 year old women show considerably lower risks of dying in all of the target periods studied, with the exception of the late fetal period, for which the risk is similar to the average one (Table 15). The advantage is greatest for the neonatal period (0.2). First births generally have a lower birth weight than children of an order greater than one. As mentioned previously, low birth weight, in turn, is a strong predictor of neonatal mortality. However, according to the ENFES data for this group of births, the adverse influence of these factors seems to be counterbalanced by the group's more favorable social conditions. These are revealed, for instance, by the average schooling, which is the highest of all the groups: 6.6 years (vs. 4.2 for all births). In addition, a full 77 percent of these births are to mothers living in urban areas (39.3 percent in metropolitan areas), the highest proportion of all the groups. Both in the neonatal and the postneonatal period, these favorable circumstances override the remaining biological effects and are expressed as a significant advantage in mortality for this group.

Later births. As can be seen graphically in Figures 7 to 9, later births to 20-34 year old mothers present increasing late fetal, infant, and childhood mortality rates, as the reproductive pace of the mothers changes from slow, to medium, and fast; and as the birth interval with the previous sibling decreases from 24 or more months to less than 24 months.

A possible interactive effect of these two variables can be observed for the case of late fetal deaths. The difference in mortality rates (relative ratios poorly-spaced over well-spaced births) is twice as big for women with a fast reproductive pace (3.0) than for those with a slow one (1.5). Late fetal mortality rates to medium fast reproducers have an even greater relative risk (3.7). In the case of infant and childhood deaths, an interaction between the effects of birth spacing and reproductive pace on mortality is less apparent. Indeed, the excess mortality of poorly-spaced over well-spaced births is practically the same for slow (1.9 and 1.5 for infant and childhood mortality) and for fast reproducers (1.8 and 1.4, respectively). Curiously enough, the corresponding relative risks for medium fast reproducers is lower than that for the slow and fast groups for both deaths in infancy (1.4) and in childhood (1.2).

When mortality rates are plotted by birth order and spacing, as well as by age of the mother at the birth of the index child (Figures 10 to 12), the following can be observed. Births to teenage mothers have, in general, higher late fetal, infant, and childhood mortality rates than births to 20-34 year old women, independently of birth order and spacing. The only exceptions are the infant and childhood mortality rates for the groups of later, well-spaced births, which show an inverted trend. This is probably due, as was explained above, to the instability of the rates for the teenage births. Furthermore, first births, both to teenagers and to 20-34 year old women, are always lower than later, poorly-spaced births. The analysis of the relative risk of dying for teens, with respect to older women for each order/spacing category, suggests a possible interaction between the variables.

As shown above, for all studied mortality periods, well-spaced births show an advantage in mortality over poorly-spaced ones, independently of reproductive pace. For women with a slow pace, the advantage in childhood mortality shown for well-spaced births (0.6) disappears for poorly-spaced ones (0.9); for women with medium pace, the difference from well to poorly-spaced births is 20 percent (1.0 and 1.2, respectively); for women with a fast pace, the corresponding difference is 42 percent (1.2 and 1.7, respectively) (Table 15). The increase in the mortality risks (for childhood) with a reproductive pace going from slow, to medium, and fast is different for well-spaced (relative risks: slow 0.6, medium 1.0, and fast 1.2) and for poorly-spaced births (relative risks: slow 0.9, medium 1.2, and fast 1.7). The group of well-spaced births to 20-34 year old women with a slow reproductive pace, together with that formed by first births to women of the same age group, are the family formation patterns, which show the greatest advantages in mortality for all the periods studied. These two patterns show similar risks for the late fetal, infant, and childhood periods. First births have the lowest risk of all the groups for the neonatal period (Table 15), whereas later, well-spaced births have the lowest risk for the postneonatal period. The one exception are the low risks found among well-spaced births to women with a medium-fast reproductive pace (Hobcraft's reference group), which have the lowest risk of dying in the late fetal period (the relative risk over the total births is 0.4).

**FIGURE 7**  
**LATE FETAL MORTALITY RATES BY**  
**REPRODUCTIVE PACE AND BIRTH**  
**SPACING 1977-1986**  
**(ENFES 1987)**

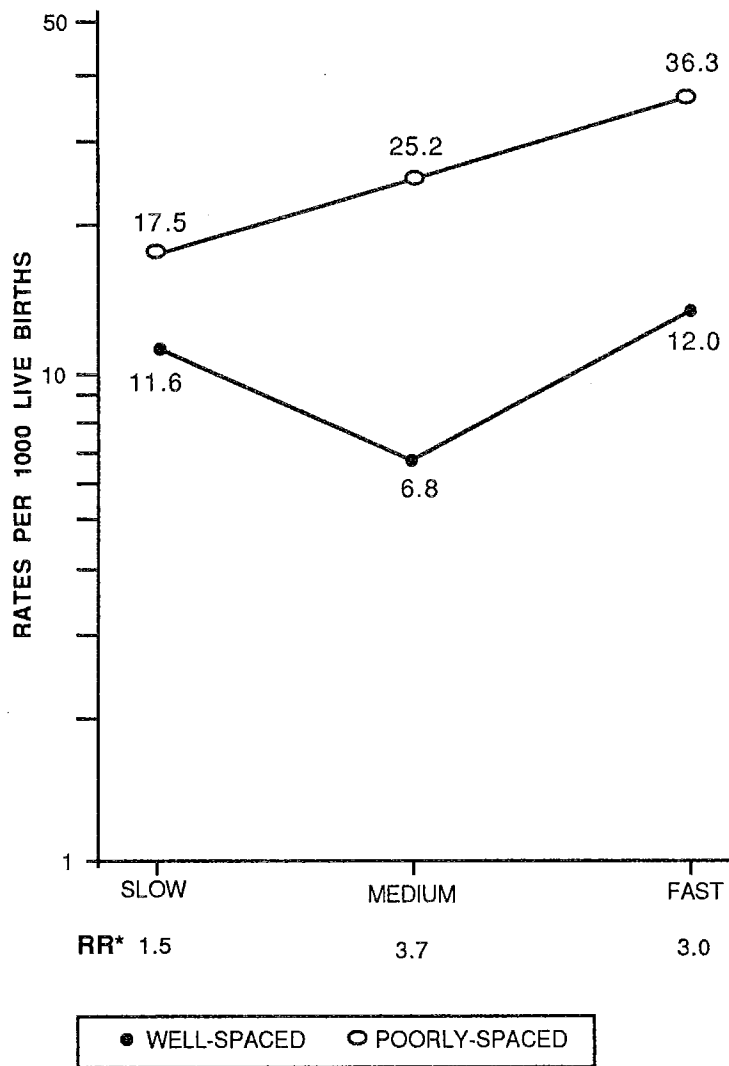

\*Relative risk poor-spacing vs well-spacing

**FIGURE 8**  
**INFANT MORTALITY RATES BY**  
**REPRODUCTIVE PACE AND BIRTH**  
**SPACING 1972-1986**  
**(ENFES 1987)**

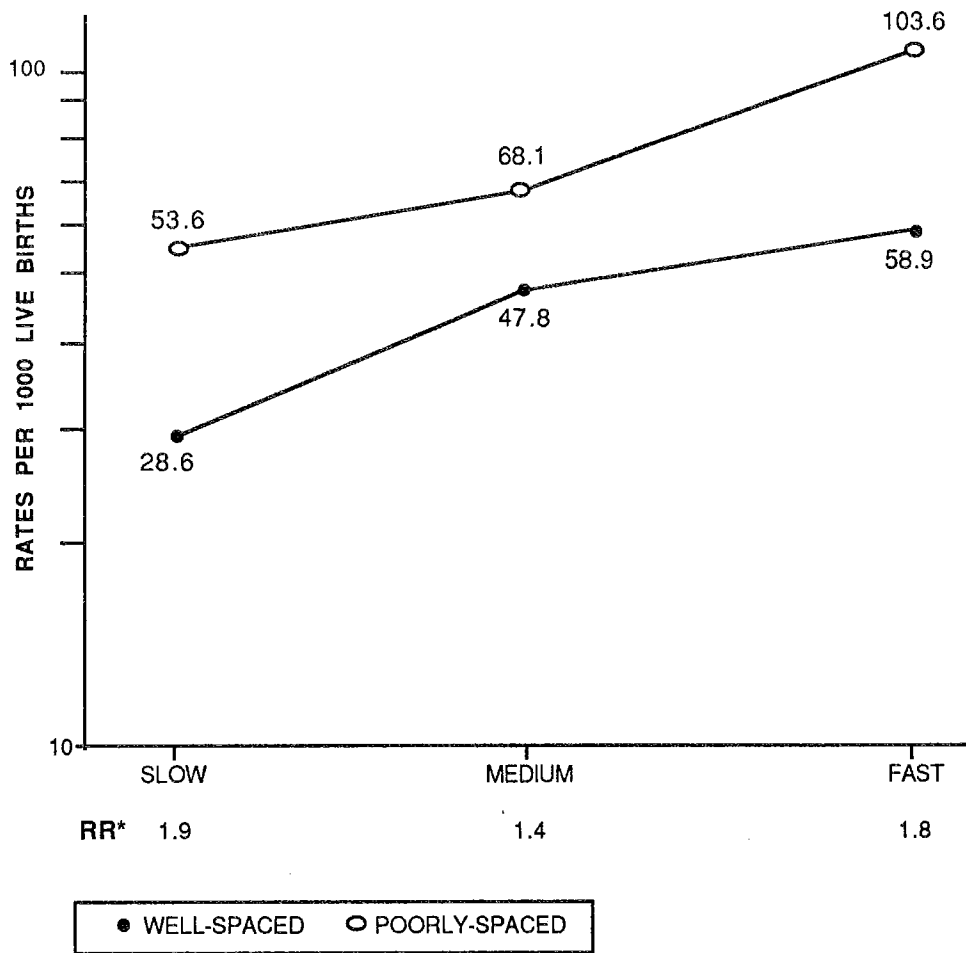

\*Relative risk poor-spacing vs well-spacing

**FIGURE 9**  
**CHILDHOOD MORTALITY RATES BY**  
**REPRODUCTIVE PACE AND BIRTH**  
**SPACING 1972-1982**  
**(ENFES 1987)**

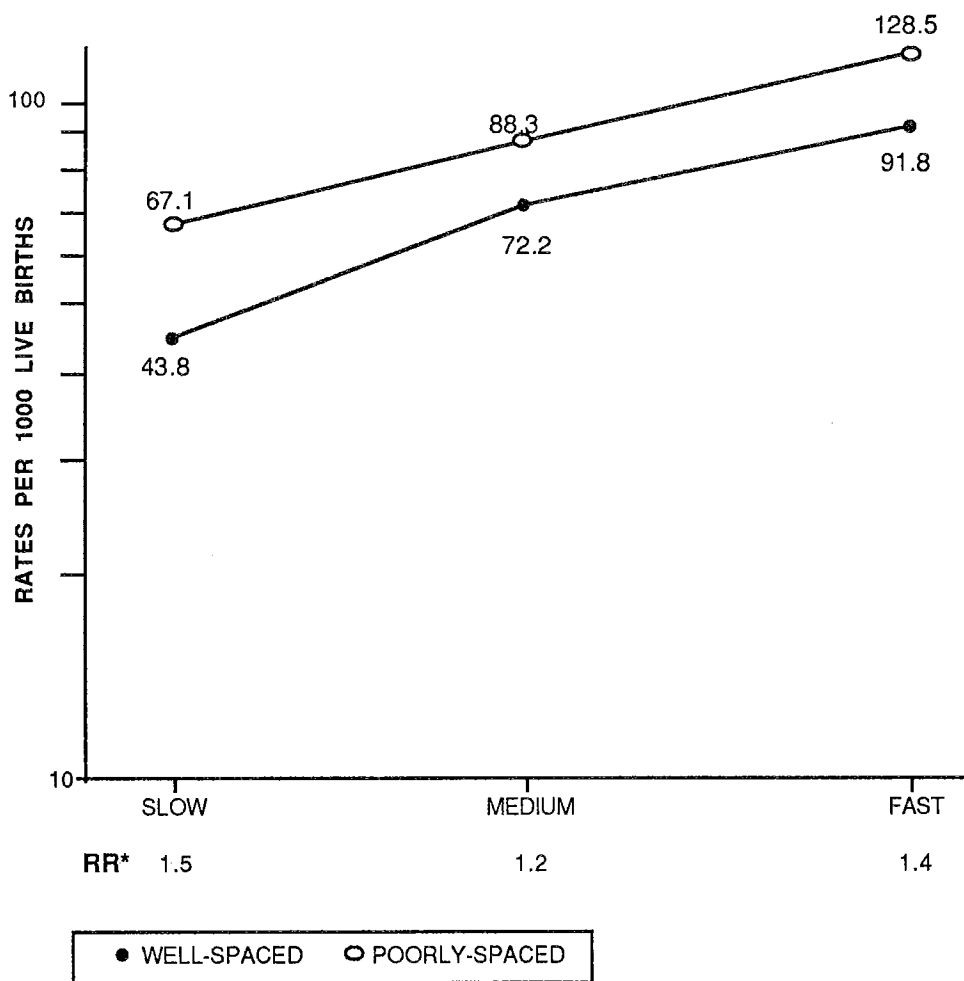

\*Relative risk poor-spacing vs well-spacing

**FIGURE 10**  
**LATE FETAL MORTALITY RATES BY BIRTH**  
**ORDER, BIRTH SPACING AND AGE OF THE**  
**MOTHER 1977-1986**  
**(ENFES 1987)**

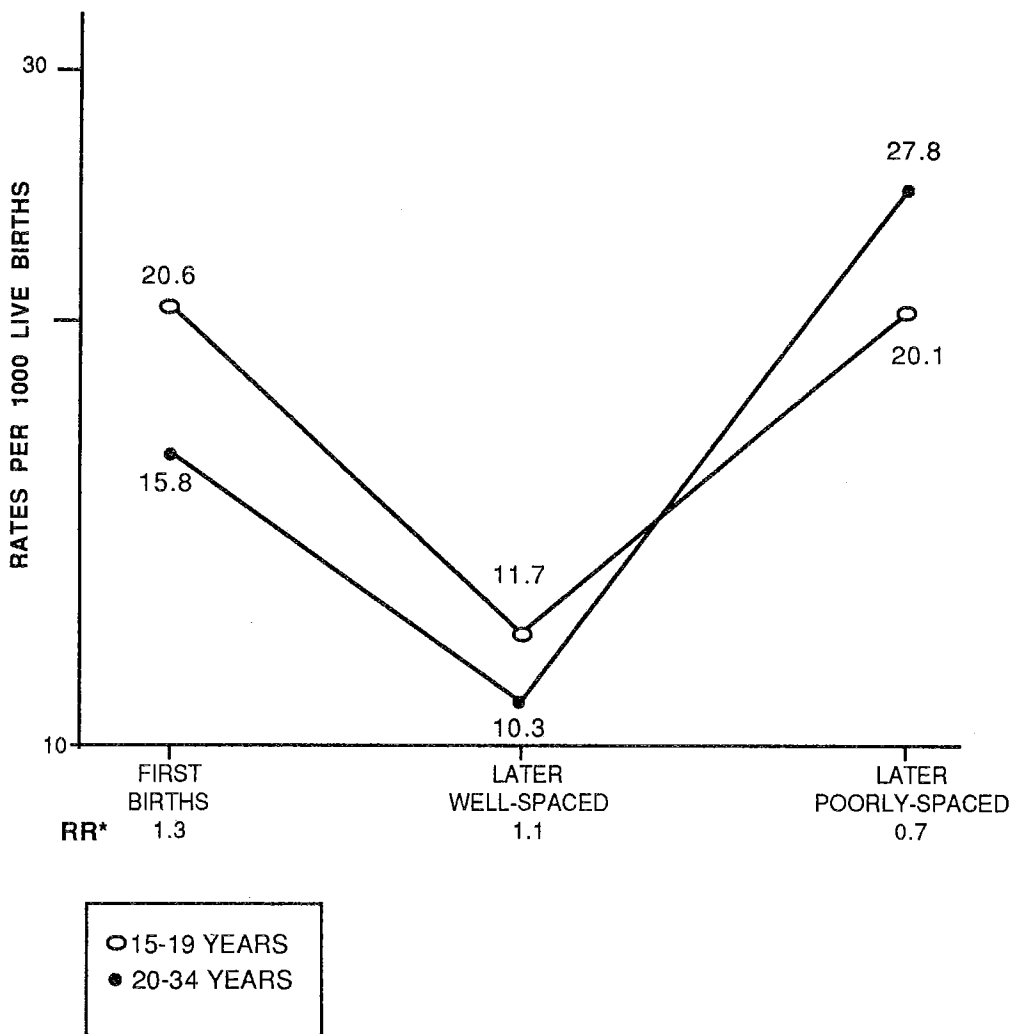

\*RELATIVE RISK: 15-19 years old over 20-34 years old

**FIGURE 11**  
**INFANT MORTALITY RATES BY BIRTH**  
**ORDER, BIRTH SPACING AND AGE OF THE**  
**MOTHER 1972-1986**  
**(ENFES 1987)**

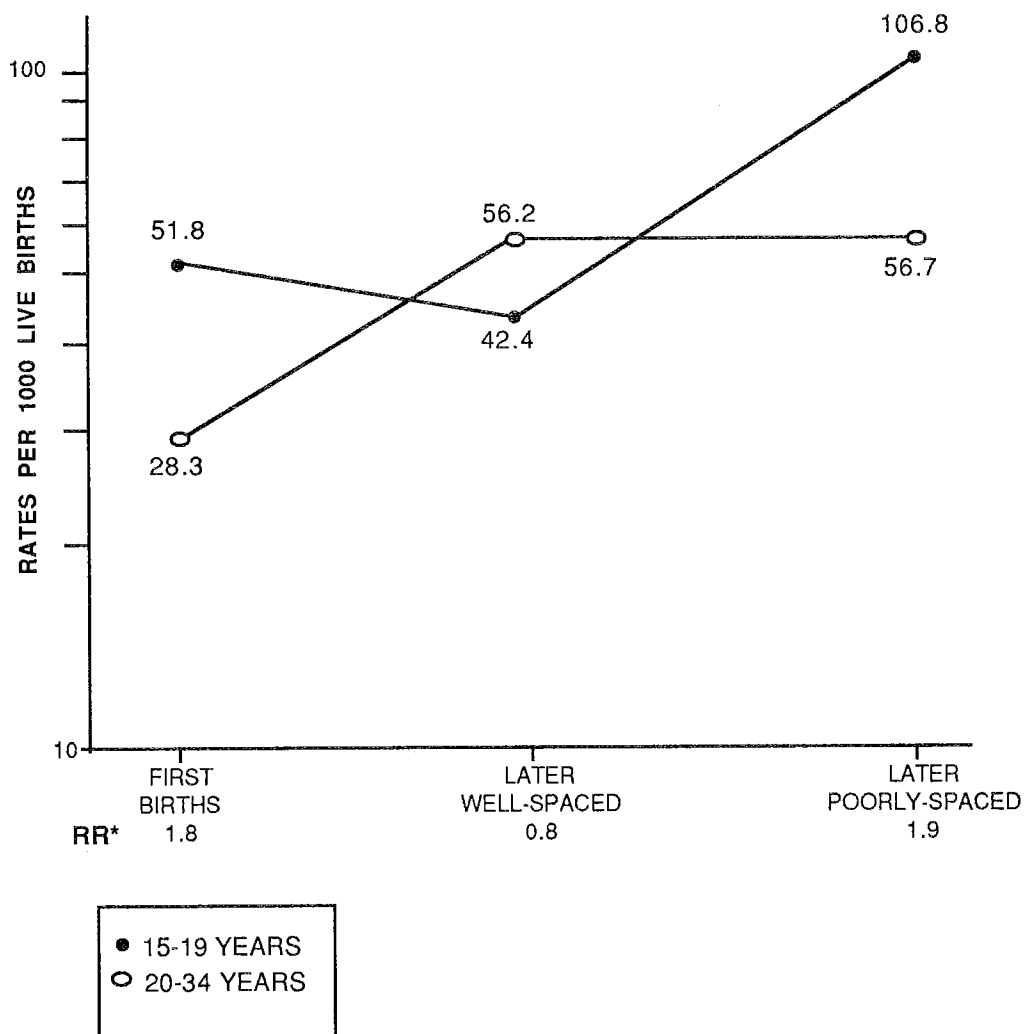

\*RELATIVE RISK: 15-19 years old over 20-34 years old



**FIGURE 12**  
**CHILDHOOD MORTALITY RATES BY BIRTH**  
**ORDER, BIRTH SPACING AND AGE OF THE**  
**MOTHER 1972-1982**  
**(ENFES 1987)**

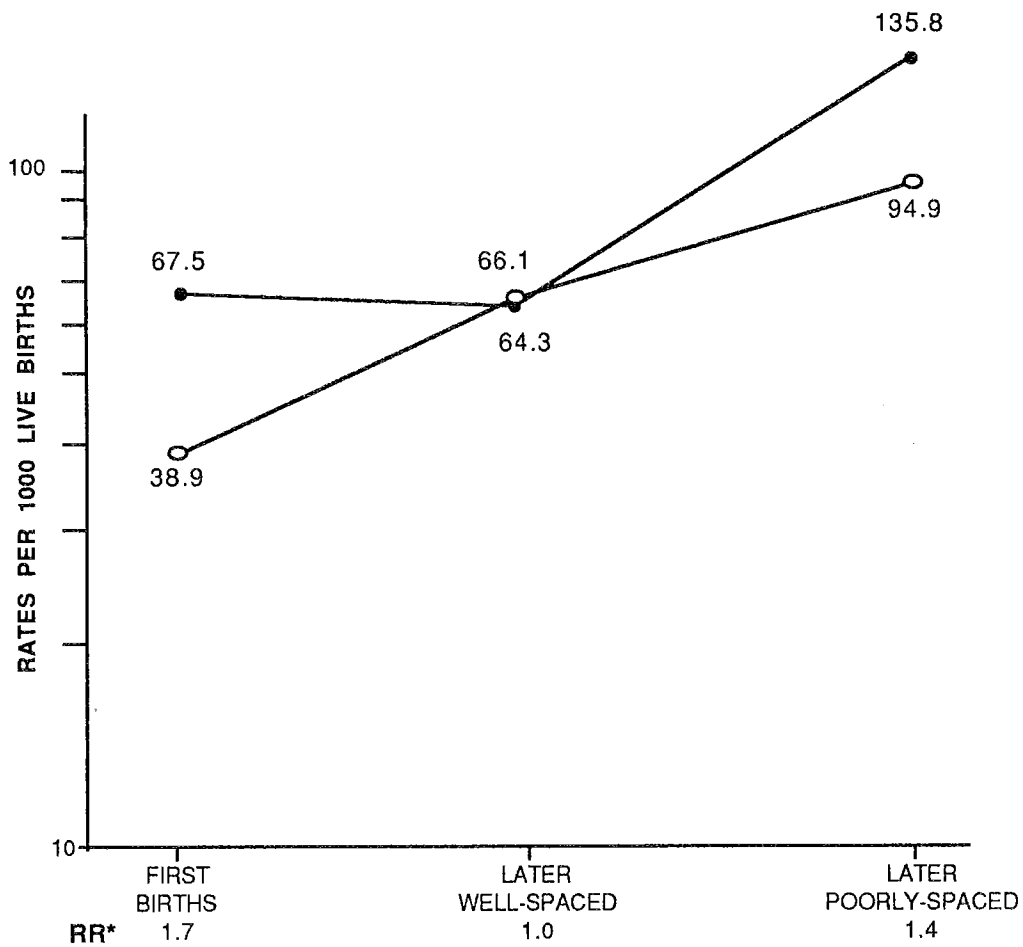

● 15-19 YEARS  
○ 20-34 YEARS

\*RELATIVE RISK: 15-19 years old over 20-34 years old

The influence of biological factors (probably via adequate birth weight), reinforced by favorable social conditions, would be a plausible explanation for the advantage in mortality conferred by belonging to the group of well-spaced births to 20-34 year old women with a slow reproductive pace. The influence of social factors is apparent in the very low relative risk of dying in the postneonatal period (0.3). Average schooling for the group is 5.9 years, the second highest after first births.

Well-spaced births to 20-34 year old mothers with a medium reproductive pace have social characteristics, which are similar to the former group of later births to slow reproducers: 57 percent of the births are to women with 3 years or less of education and 44 percent to women living in communities with less than 2,500 inhabitants. However, average schooling is lower (3.5 years). Adjusting for schooling and community size does not affect the raw relative risks of dying, either in infancy or in childhood. The strong protective effect of this pattern towards late fetal and also neonatal mortality is suggestive of biological mechanisms.

Among poorly-spaced births, the proportion born to mothers with the most unfavorable social conditions (up to 3 years of schooling and living in communities with less than 2,500 inhabitants) rises from 18.8 percent for women with a slow reproductive pace, to 28.1 percent for those with a medium pace, to almost 40 percent for those with a fast pace. Average schooling decreases correspondingly from 5.2 to 3.8 and 2.8 years.

Poorly-spaced births to slow reproducers show average risks for the infant and childhood periods. Poorly-spaced births to women with a medium reproductive pace have relative risks of dying slightly higher than average for all the mortality periods (1.2 to 1.4). The risk for the postneonatal period is the highest.

Poorly-spaced births to women aged 20-34, who are fast reproducers, together with poorly-spaced births to teenagers, are the two family formation patterns, which proffer the greatest disadvantages in terms of childhood survival. The former group has the highest risks for late fetal (1.9) and neonatal (2.4) mortality of all the groups with respect to the average. The latter group, besides having a high relative risk for neonates (1.7), shows the highest relative risk for the postneonatal period (2.4). The mechanisms through which the association between family formation patterns and mortality operates seem thus, to be chiefly socially determined for the teenage births and biologically determined for the 20-34 year old fast reproducers. In this latter group, the effect of the involved biological factors is most probably reinforced by unfavorable social, economic, and environmental factors, as noted above. Hobcraft (1987) mentions that the great excess mortality in this group arises partly from the fertility consequences of past child losses in high-risk families. Competition for mother's care, maternal depletion, and inadequate compensatory health care are all variables, which are related to the socioeconomic level of the families and which could partly explain the excess mortality of this group (Pebly and Millman, 1986; Winikoff and Castle, 1987).

### Births to Older Women

Another group, which behaves in a manner similar to the total population, is composed of the births to mothers 35 years of age and older (Tables 14 and 15). The one exception is the late fetal mortality rate (29.6), which is well above the average (19.0). In fact, it is the second highest of all the family formation patterns, following that of births to 20-34 year old women with a fast reproductive pace and poor spacing (36.3). A high incidence of congenital anomalies and a progressive, age-related decrease in utero-placental blood flow to the fetus have been linked with births at very high maternal ages.

On the other hand, the mothers of this group show the lowest educational level of all the groups (average schooling: 2.6 years; 40 percent of the births to women with no schooling at all). Most of the births (64 percent) are to women living in rural areas (44 percent in communities with less than 2,500 inhabitants). One can say that, in spite of these unfavorable characteristics, the family formation pattern constituted by older women (>35 years) is not exposed to excess mortality, except in the late fetal period.

Summarizing, it would appear that there are three main types of family formation patterns, as judged by their mortality rates. First, patterns which show, in general, average mortality rates and could be considered baseline patterns. This group is represented, for instance, by the first births to teenage women or all the births to older women (35 or more years of age). The second pattern consists of those with mortality rates, which are higher than average. These are high-risk groups with poor fertility control: a) later, poorly-spaced births to

teenagers; and b) later poorly-spaced births to 20-34 year old mothers with either a medium or a fast reproductive pace. Finally, there are patterns which seem to act as protectors from child mortality. They are associated with good fertility control and consist mainly of first births to 20-34 year old women and later, well-spaced births to mothers in the same age group with a slow reproductive pace.

A stratified analysis of the association between family formation patterns and mortality, controlling for social variables, such as schooling and size of the community of residence of the mother, was attempted for infant and childhood mortality. As expected, the numbers in most of the cells were very low. For this reason, they are not presented here. Generally, the direction of all the trends found in the bivariate analysis was maintained. Adjustment was thus performed by means of multivariate analysis based on statistical models, and the results are presented below.

### **Multivariate Analyses**

Tables 16 and 17 show the estimated coefficients of the logit models fit to the data in the four different mortality periods of interest. The coefficients are the estimated odds of death relative to the geometric mean of the effects of a variable. Ratios among them lead to odds ratios as estimates of the relative risks. Four different models are presented: The first one with the variable family formation patterns as the only explanatory variable; the second model adds the effect of mother's education; the third one adds the effect of the size of the community of residence; finally, the fourth model controls simultaneously for the effects of both variables, mother's education and community size. In the latter model, the effects of both variables were statistically significant. Effects of other variables, such as gender or contraceptive use, did not prove to be as significant, after controlling for the two previous variables.

### Infant Mortality

The relative odds for family formation patterns without adjusting for other variables (model 1), indicate that the patterns showing the highest risks of death are those formed by subsequent poorly-spaced births to teenage mothers and by later poorly-spaced births to mothers aged 20-34, with a fast reproductive pace (Table 16). Relative to the effect of all patterns, the odds of death in these patterns are greater than two. A protective effect against mortality is found for first births to mothers 20-34 years old and for later, well-spaced births to mothers 20-34 years old with a slow reproductive pace. The relative odds of death are about 0.5 for these last two patterns. The relative difference of mortality probabilities between patterns with extreme relative risks is between 3 and 4. The above figures may be adjusted through the multiplication by the baseline odds, 0.0572, which is an estimate of the mean level for the odds of mortality for all children in the sample after taking into account the effect of the family formation patterns. In fact, the baseline odds is the reference value, from which the effects of the family formation patterns can be measured.

The estimated effects for the first model correspond to the relative (raw) risks reported in Table 16. They are confounded, among others, by the variable maternal education. When this variable is added to the logistic model, the effects of the family formation patterns of the new model are slightly modified. For example, without the inclusion of mother's education, the estimated effect for the pattern corresponding to first births to 20-34 year old women is 0.5193, whereas the corresponding effect for the model, including that variable, is 1.1443. This means that part of the crude effect on infant mortality for this pattern is due to the fact that there is a relatively greater proportion of women with higher levels of education in this pattern, and education acts to lower infant mortality. When this is accounted for, the effect of belonging to the pattern of first births to 20-34 year old women on mortality, is increased. The opposite behavior may be seen for the pattern corresponding to subsequent poorly-spaced births to mothers aged 20-34 years with a fast reproductive pace. In this pattern, there are proportionately more women with low levels of education.

An analogous interpretation can be given for the effect of the variable, mother's education, on mortality: The estimated odds relative to the geometric average are 1.20, 0.95, and 0.88 for the first, second, and third categories, respectively (lower section of Table 16). Although these effects may still be confounded by those of the community of residence, their behavior appears very reasonable. They reflect a decreasing gradient in the risks of mortality, as the level of maternal education rises.

Community size proved to be statistically significant after adjusting for maternal education. The effect of this variable on infant mortality can be seen in the estimated odds for this variable in models 3 and 4 (see [Table 16](#)). There is a clear negative gradient as community size increases.

Net effects of the family formation patterns on infant mortality (adjusted by mother's education and community size of residence) are shown in the last row of the upper section of [Table 16](#). From this model, it is apparent that subsequent births to teenage mothers with short birth intervals are the ones with the highest risk of infant death. By contrast, the pattern formed by subsequent well-spaced births from mothers 20-34 years old with a slow reproductive pace is the one with the lowest risk of death.

The influence that maternal education or community size has on infant mortality (adjusted for the effect of the remaining variables) is large: Children of uneducated mothers (0 years of schooling) have more than one and a half times (1.7) more chances of dying during their first year of life, than children of educated women (7+ years of schooling). A similar relationship holds between children born in large cities (Mexico, Guadalajara, and Monterrey), as compared to those born in localities with less than 2,500 inhabitants (1.5). However, such effects are smaller than those estimated from the crude associations (see [Table 9](#)).

It is to be noted that the raw odds estimated by model 1 do not change very much after controlling for the two variables. This behavior can be explained by the differential distribution of births in each pattern across the different levels of education and community size. Relative risks of death for each pattern should be calculated from the odds estimated by model 4, since confusion effects of the two social variables have presumably been eliminated.

#### Neonatal and Postneonatal Mortality

It is to be remembered that the interpretation of the findings resulting from the disaggregation of the period from 0 to 11 months of age into its neonatal and postneonatal components has to be undertaken with care, due to the possible occurrence of a transfer of postneonatal to neonatal deaths. However, the following results are illustrative.

For the neonatal period and according to the complete model, the effect of mother's education appears to be less important than for the entire infancy period. The chances of dying for a baby born to uneducated women (0 years of schooling) are 1.4 times those for a child born to an educated woman (7+ years of schooling). The corresponding figure for infancy is 1.7. This implies that, although the risk of mortality during the first month of life is attenuated in the presence of good socioeconomic conditions, the importance of biological (fertility-related) factors is greater.

On the other hand, the effect on neonatal mortality of the other control variable (community size), is similar for the neonatal and for the infant period. In both cases, the odds of death are 1.5 times higher for children born in communities with less than 2,500 inhabitants than those for children born in very large urban communities.

The pattern formed by poorly-spaced births to 20-34 year old women with a fast reproductive pace has the highest risk of neonatal mortality. The odds of death are 2.4 times higher than the geometric average of all categories. As can be noted in this pattern, there is a very high proportion of rural women with a low educational level.

The protective effect of high educational levels on postneonatal mortality is very strong indeed. Children born to mothers with no schooling at all have relative risks of death that are twice as high as those of children born to educated mothers (7 and more years of schooling). This implies that better socioeconomic conditions, as reflected by maternal education, have a strong influence in preventing the death of children after their first month of life, whereas the effect of biological factors is less important.

The effect of community size is also strong and very similar to the one observed for the entire infant period. Children born in rural areas (less than 2,500 inhabitants) have a risk of death 1.5 times higher than babies born in large cities. Poorly-spaced births to teenage mothers have, by far, the greatest risk of death. These births

have an almost 2.4 times higher risk of death than the average risk for all the categories. Poorly-spaced births to 20-34 year old, fast reproducers also show a high risk of death: 1.3 times higher than the average risk for all of the categories. A protective effect is observed for first births and all the categories of well-spaced births to 20-34 year old women.

### Childhood Mortality

The estimated effects for childhood mortality reveal striking similarity with those for infant mortality. In fact, almost all of the conclusions stated for the relationship between infant mortality and the family formation patterns are valid. The patterns formed by poorly-spaced births to either teenagers or to 20-34 year old mothers with a fast reproductive pace are the ones with the highest risks of childhood mortality. On the other hand, first births to 20-34 year old women and later, well-spaced births to slow reproducers of the same age group show the lowest risks of death.

In Tables 16 and 17, it can be noted that controlling for schooling and community size does not substantially alter the results obtained with the bivariate analysis. The inclusion of these variables in the complete model is justified by their respective, adjusted effect on mortality. Indeed, for childhood mortality, the relative risk of dying of births to mothers with less than 3 years of schooling in comparison to those of mothers with 7 or more years is 1.6. The corresponding relative risk of births to mothers living in communities with less than 2,500 inhabitants against those to mothers living in metropolitan areas is 1.7.

The explanation for the above lies in the multiplicative character of the risks. If a child is born to a mother with a protective family formation pattern (e.g., he is a first birth to a 20-34 year old mother), his (adjusted) risk of dying in the first five years of life is 0.63 as compared to the average child (model 4 in Table 17). However, this risk changes if we take into consideration the educational level of his mother and the type of community she lives in. So, for instance, this risk (0.63) has to be multiplied by 1.35 if the mother has 3 years of schooling or less and by 1.31, if she lives in a community with less than 2,500 inhabitants. In this manner, the risk for that child increases to 1.11. By contrast, if the child was born to an educated mother with 7 or more years of schooling and living in a metropolitan area, the risk of his dying in childhood becomes only 0.41.

Tables 18 and 19 show the relative risks of dying in infancy and in childhood, respectively, for all the education and community size categories, as well as for all the family formation patterns. In these tables, the expected gradients along education and community size categories are clearly seen in each of the family formation patterns.

The association between the FFP and the probability of dying in childhood is very strong. After controlling for other socioeconomic variables, a baby born after a short interbirth interval to 20-34 year old women with a fast reproductive pace has 2.5 more chances of dying before age 5 than a baby born after a long birth interval to a mother of the same age, but with a slow reproductive pace. Compared to the other variables studied, FFP is the strongest predictor of mortality. The crude association of mother's education with childhood mortality is 2.5; when adjusted for the FFP, the strength of the association declines to 1.3. The comparison groups are, in the lower end, women with 3 years or less of schooling and, on the other end, women with seven years or more of schooling. This strongly suggests that most of the effect of maternal education on mortality is due to the strong correlation with the FFP. In other words, the mechanisms by which education influences childhood mortality, operate by changing the fertility rate, as a result of an increase in the number of births to women with favorable family formation patterns. The remaining direct effect of education on mortality is moderate.

The effect of the size of the community of residence of the mother on mortality does not seem to be mediated through the FFP. The crude relative risk of mortality for babies born in rural areas (with less than 2,500 inhabitants) is about twice that for births occurring in metropolitan areas. Once FFP is controlled for, the adjusted relative risk of childhood deaths in rural areas remains very similar to the crude relative risk. This means that, although the size of the community was strongly correlated with the FFP, its impact on childhood mortality is independent of the FFP.

In relation to the dependent variable, it is worth remembering that childhood mortality is often conceptualized as a health indicator. Even if mortality is associated with ill health, there are a large number of health problems, which do not necessarily result in mortality. This is true, nowadays, for many diseases including those associated with mortality in the past, such as acute diarrheal disease. In effect, new interventions have been developed, which influence mortality but have no impact on the incidence of disease, such as oral rehydration therapy. Three health problems common in children are not well represented by mortality. Moderate malnutrition is not associated with a higher incidence of common causes of mortality, such as diarrhea and acute respiratory infections (Sepulveda, 1986) and could have a different association with the FFP. Intestinal parasitosis is not directly responsible for deaths in children and is known to be highly prevalent in developing countries. Finally, many of the complications of pregnancy and labor are expressed as mild impairments in hearing, visual acuity, timing of development, etc. A fourth group consists of the psychological problems of children, which are known to be closely related to the dynamics of the family.

Overall, mortality is a good health indicator in countries or societies with a high level of mortality. On the other hand, it is a rather crude measure of health status in societies with low or moderate childhood mortality. Family formation patterns may have presented a different association with child health, had a more sensitive indicator been chosen, instead of mortality. The best example of this is represented by births to teenage mothers. For them, mortality is not necessarily higher than for births to women aged 20 years and above; however, their neurological development may be impaired.

It is worth noting that late fetal mortality is known to be composed by two different types of deaths, which have not been differentiated in this project: the antepartum and intrapartum fetal deaths. The former is associated with a variety of problems related to the blood supply to the growing fetus. The second is more associated with complications during labor. Paneth et al. (1985) have shown that variables, such as age and parity of the mother, are associated in different ways with the two types of deaths. For example, maternal age of 35 years and above was found to be related to a higher frequency of antepartum deaths but not of intrapartum deaths. The opposite trend was found for high parity. Further research should attempt to differentiate the effects of FFP in these two periods.

### **Comparison with 18 Developing Countries**

In the following section, the results of this study are compared to those reported by Hobcraft (1987) for 18 developing countries. The measure of association is the relative risk of dying in any specific FFP, in relation to the overall mean mortality rate.

In the interpretation of the magnitude of the relative risks, we adopt limits of 1.50 for the upper end and 0.66 for the lower end. Relative risks, which are within the above interval, i.e., which are close to unity, are interpreted as being nonsignificant from the public health point of view. More importantly, relative risks with values comprised between 0.67 and 1.49 could easily be explained by a confounding third variable not controlled for in this analysis. Although the above limits were set in a rather arbitrary manner, previous empirical research based on observational studies of multicausal health problems, has shown that such small relative risks tend to show associations, which later are proved not to be causal. Larger differences are, of course, in no way a demonstration of causality, but they leave less uncertainty as to the possible role of a third unmeasured variable.

A third common variable with a strong influence on both FFP and mortality in childhood is more likely to be biological than social. Indeed, moderate malnutrition of the mother is known to be causally associated with a poor pregnancy outcome and possibly with those family formation patterns related to conditions of uncontrolled fertility. This variable will be discussed further in a later section.

### Young Age

Contrary to previous findings, in this study young age per se was not found to be associated with higher childhood mortality rates, except for poorly-spaced births. In the ENFES sample, 26 percent of all births to teenage women are later births with a short previous birth interval. The results reported here are very consistent with those reported by Hobcraft (1987). The relative risk of childhood death among first births to teenage

mothers is close to unity, consistently for Mexico and the 18 countries studied by Hobcraft (Table 20). This table was derived from the original one, in which the reference category was conformed by later births to 20-34 year old mothers with a medium reproductive pace. This is why, in the original table, the risks for most countries are above 1.3. In Table 20, the relative risks were recalculated in relation to the total sample of births. (For the ENFES data, the women age 35 and above were excluded for the sake of comparison.)

The relative risk of mortality for births to teenage mothers, as compared to those of 20-34 year old women, is higher in Mexico and in the other countries, with the only exceptions of Cameroon and Jamaica. In Mexico, the excess of mortality among first births to teenage mothers is 60 percent (RR = 1.57). In the other Latin American countries, the relative risk is similar to the one obtained for Mexico, except for Costa Rica, where the excess is 100 percent (RR = 2.0).

It is very important to note that the difference between the mortality rates of first births to teenage mothers and to older women is due to the protective effect of increased age among first births and not to an overall increased risk among births to teenage mothers. The mechanisms involved in the protective effect of age among first births are probably related to cultural and social attributes of the women, who are able to postpone childbearing until the third decade of life. This is supported by the fact that the protective effect of age is not so strong in the late fetal and neonatal periods, as compared with the postneonatal one. A clear downward gradient of the relative risk of mortality among first births of teenage mothers as compared to first births of women 20-34 years old, can be seen through the three periods. In the late fetal period, the relative risk is 1.30, and it reaches 1.36 in the neonatal and 2.1 in the postneonatal period. This is due entirely to the lower rates of postneonatal mortality among first births to women age 20-34 years.

Women who delay childbearing after age 20 probably have a better control of decisions related to hygiene, food distribution, prevention of disease during pregnancy etc. within the household. More importantly, they are more able to identify early signs and symptoms of severity.

#### Birth Intervals

Short interbirth intervals with the previous sibling are associated with a greater risk of death in childhood, both among teenagers and among women aged 20-34 years. Poorly-spaced births always show higher mortality rates than births with a long birth interval, irrespective of the reproductive pace. This provides added evidence for the significant effect of this variable on childhood mortality. These results are very consistent with those reported by Hobcraft (Table 20). All the countries show rates of childhood mortality, which are above the mean for poorly-spaced births to fast reproducers; eight countries have a relative risk higher than 1.5, six of them being from the Latin American and the Caribbean regions.

It is interesting to note that the higher rates of childhood mortality among poorly-spaced as compared to well-spaced births, within each reproductive pace category, are present in all of the 18 countries studied by Hobcraft. The mechanisms involved in the effect of spacing are most likely biological and associated with the reproductive efficiency of the mother. This is strongly supported by the consistent association between spacing and mortality in all of the age groups. Of particular importance is the higher risk of late fetal death for poorly-spaced births, which is as strong as for the other periods. This evidence adds new information for the discussion prevailing in the literature about the mechanisms involved in the causal relationship between spacing and mortality. Two of the proposed mechanisms can be questioned and may be overruled. They are the hypotheses of competition between children for the same resources (Hobcraft, 1985; Pebley, 1989) and the hypothesis of early weaning and discontinuation of breastfeeding.

Assuming that the relationship is causal, the most likely mechanism is nutritional. Short intervals could lead to an incomplete recovery of the endometrium of the uterus. The placenta would, in turn, be smaller, leading to a suboptimal blood perfusion to the fetus. The newborn would be smaller, weigh less and be therefore more susceptible to dying in the late fetal period (mainly during labor) and in the neonatal and postneonatal periods.

If only this mechanism were operating, one would expect that the strength of the association would be stronger in the late fetal and neonatal periods and weaker in later periods. Unfortunately, we do not have the sufficient number of deaths in the preschool period that would allow us to evaluate the effect of spacing on mortality after one year of age. The fact that the effect of spacing is still very strong in the postneonatal period is difficult to interpret in the light of the low educational level of the women with poor spacing and of the possible transfer of postneonatal deaths to the neonatal period.

Teenage women with later poorly-spaced births are the group with the greatest risk of dying in the childhood period. The relative risk is 1.9, as compared to the overall rate of child mortality. This relationship can also be found in the other 18 countries presented in [Table 20](#); all the countries (including Mexico) have relative risks greater than one, although only eight have values above 1.5. Four of the seven Latin American and Caribbean countries have a relative risk greater than 1.5. Mexico and Malaysia have the greatest relative risks (1.88 and 1.95, respectively).

The strong interaction between high parity and young age reported previously can probably be explained by the effect of spacing. The effect of spacing, however, seems to be stronger in teenagers than in the 20-34 year old age group, since the relative risk (1.88) for the former group is greater than for all other subgroups of poorly-spaced births, i.e., with slow, medium, and fast reproductive paces ([Table 20](#)). In other words, the combination of short spacing with young age seems to produce a greater risk of death than what is expected, the added effect of the two variables suggesting a strong synergism.

In order to gain new insights into the mechanisms involved in the likely causal association between the spacing of births and child mortality, it would be extremely useful to control for the nutritional status of the mother at the beginning of childbearing and to estimate the intrafamily risk of mortality. These variables, together with data on birth weight, would tell us whether there is some selectivity of women, according to their having a poor nutritional status or a high intrafamily mortality risk. In addition, the role of birth weight would become clearer, since it too depends on the existence of a common family risk. With the available data, it is possible to partially control for intrafamily risk, by analyzing separately the poorly-spaced births of children, who had a previous sibling who died. It is known that the effect of prematurity is present in all of the short birth intervals. However, in the ENFES sample, information on the length of gestation was not collected, so that this effect cannot be adjusted for.

### Reproductive Pace

This variable is a composite index that combines parity with age of the mother. It is particularly appropriate for the analysis of the truncated sample of births, such as those obtained in demographic surveys, since it renders parity more comparable across the age groups. In this sense, it is superior to the absolute value of parity. It is, of course, a variable strongly influenced by the fertility level; the lower the fertility, the fewer the births from fast reproducing women.

The rates of mortality among births to women with a fast reproductive pace are twice as high than among births to women with a slow pace. This is true in the infant and the childhood periods. The neonatal and postneonatal periods are possibly affected by the transfer of deaths from the latter to the former period, in some of the groups.

The results reported by Hobcraft show that the effect of reproductive pace is very strong only in some of the countries. [Table 21](#) shows the relative risk of child death for births to fast reproducers, according to the adequacy of birth spacing and to the mortality level for 19 countries. The countries which show a significant difference in the relative risk of death between the poorly-spaced and the well-spaced births are those with moderately high levels of mortality (40-80 deaths per 1,000 live births) and Thailand. In this group of countries, the mean relative risk for the poorly-spaced births is 2.11, ranging from 1.55 in Costa Rica to 2.87 in Trinidad and Tobago. The remaining countries show very similar relative risks for the two groups of births. In actual fact, the countries with very high mortality rates (around 200 deaths per 1,000 live births) show no difference in risks at all, except for Senegal (1.56 vs. 1.06).



We have no explanation for the extremely high risk of the well-spaced Mexican births. Is the association between reproductive pace and childhood mortality real? To answer this question, it is necessary to control for the risk of childhood mortality of the family. Mothers of families with an intrinsic risk of child death have higher parities at all ages. By and large, this effect is due to the high intrinsic risk. This operates through the desire for replacing the dead children by new ones who will survive. In order to control for intrafamily risk, a different set of data is needed in which women with completed fertility are studied and for which the overall intrafamily level of mortality can be estimated. In addition, the unit of analysis needs to be the family and not the child.

## V. CONCLUSIONS AND POLICY IMPLICATIONS

### Conclusions

1. The research conducted indicates the relevance of changing patterns of reproduction. Mexican families are passing through a strong process of cultural and socioeconomic transition. The increasing curtailment of the number of total children per couple provides, without any doubt, strong evidence of the changing values and attitudes towards children. In addition to this quantitative aspect of reproductive behavior, this project has provided information on a qualitative transition of the patterns of reproduction in Mexico. It is worth noting that the reduction of fertility, per se, does not necessarily produce positive changes in the FFP. Mexico showed that the overall trend is positive, since the shifts are from fast to slow reproductive pace and from short to long intervals. However, in other societies, where breastfeeding is an important way of spacing births, the introduction of contraception is giving way to a shift from long to shorter birth intervals.
2. Childbearing in the teenage years is not associated with higher mortality. However, higher mortality rates arise when several and closely-spaced children are born. Women who start childbearing in the early teens are a high risk group, and efforts should be made to prevent them to have further closely-spaced pregnancies. First births in adolescence are at no special risk, although this may be different for very young girls (below 17 years of age).
3. First births are not associated with higher childhood mortality. The best time to start childbearing is in the 20s. This age group was the one for which the lowest risks were found, even after adjusting for socioeconomic variables.
4. Having too many children is not associated with higher mortality per se. However, spacing makes a big difference. Having many children with short birth intervals leads to very high risks of childhood death, but with adequate spacing, the risk is not increased.
5. Childbearing at age 35 and above is not associated with higher mortality in childhood. The only exception is for the higher rates found for the late fetal period and for congenital malformations.
6. Short interbirth intervals are associated with a higher risk of death in childhood. Irrespective of any other variable, short birth intervals lead to higher mortality. Women in their teens with several closely-spaced births have children with very high rates of mortality in childhood. The same is true for 20-34 year old women, who have too many poorly-spaced children.
7. The speed of reproduction is associated with moderate increases in mortality. Fast reproductive pace is associated with higher rates of mortality, although the association depends strongly on the spacing. For well-spaced births, the deleterious effects of the fast pace are practically offset.
8. The effect of education of the mother on infant mortality is largely mediated by differences in the family formation patterns among the educational groups. Further research is warranted in order to assess to what extent this finding is due to causal relationships.

## Policy Implications

According to the results of this report, the decline of fertility in Mexico has been accompanied by positive changes in reproductive patterns. These changes, in turn, have made a positive impact on the survival of children under 5 years of age. This has occurred despite the fact that the family planning programs, during most of the period they have been operating, have not actively sought women with higher risks of infant or childhood mortality.

It is reasonable to expect greater benefits from a further fertility decline, if high-risk women are warned about their higher risk and supported accordingly. Support should consist in: a) rendering the means for adequate fertility control (mainly through contraception) accessible to the women; and b) providing adequate medical care in order to prevent a negative health outcome, should the women desire more pregnancies.

It is estimated that by manipulating the FFP of the Mexican women, reductions of 27 percent in the infant mortality rate can be achieved. This figure was obtained by standardizing the infant mortality rate of two groups of births that differed in the level of their mother's education. The total infant mortality rates for each FFP were used as the standard. They were applied to the actual number of births in each FFP, in the two groups. The difference in the resulting infant mortality rates between the group with higher education (7 or more years of schooling) and the one with lower education (3 or fewer years of schooling) was found to be 27 percent. Expressed in terms of relative risks, it becomes 1.38. If other variables are held constant, the lower educational group experiences a 38 percent higher mortality than the one with higher education, which is due exclusively to differences in the patterns of reproduction between the two groups. This excess mortality represents about 25 percent of the difference in unstandardized infant mortality rates between the two groups. In other words, if all the women of the low education group were to reproduce with the pattern of the high education group, the excess mortality would be reduced from 2.55 to 1.85.

We envisage, thus, three possible ways of contributing to lower childhood mortality. They will be discussed presently.

Health education: The population at large should be informed of the greater risks of childhood mortality associated with specific patterns of reproduction. Although there are good reasons for simplifying research results when they are disseminated to the population, it is of paramount importance not to incur errors. More specifically, women with high parities and older ages should not be associated with high-risk groups.

The lay public should be acquainted with the fact that patterns with poor spacing are related to an increased risk of death. There is sufficient evidence to support the hypothesis of a causal association, despite the fact that the mechanisms through which they operate are still unclear.

Teenage pregnancy is associated with higher mortality only when poor spacing is present. Primigravid teenagers constitute a health education target. They should be educated about the high risk of having more children after short intervals.

On the other hand, it is important to inform those social groups, which already have certain control of their fertility, about the protective effects of some reproductive patterns. The message should be to start reproductive life in the 20s, to have interbirth intervals of 2 or more years, and to have no more than 3 children by age 25, and no more than 4 by age 34. There are reasons to believe that health education related to reproduction is best assimilated during the school years. A study on the feasibility of incorporating this information in primary-school textbooks is warranted.

Family planning as a preventive intervention: Women with high risk of childhood mortality, according to their reproductive pattern at the time of the last birth, should be encouraged to change it accordingly. Several opportunities in medical settings are probably lost, by not identifying and advising high-risk groups. Target women include those with short interbirth intervals, even at the beginning of their reproductive life. On the other hand, women with many children are often mistakenly considered to be at high risk of childhood mortality and, on occasion, they are blamed and labeled as "irresponsible."

Very recently, Mexico has launched a new phase in the family planning program, concentrating efforts in the rural areas of eight poor Mexican states. This program has set health objectives (in addition to the usual demographic ones), which include the improvement of the chances of childhood survival. The program could have a greater impact on child survival if it were to incorporate the present results for the identification of high-risk women. More specifically, women in the rural areas who refuse to reduce the number of children could, perhaps, be convinced to space their pregnancies better. Teenagers are a priority group for the reasons previously given. Perhaps in the rural areas, the information on the protective effects of certain family formation patterns is less relevant, since most of these patterns are associated with low levels of fertility. However, this should be investigated further.

Adequate perinatal care: Medical care during labor and soon after birth is particularly effective in reducing morbidity and mortality in the fetus and the newborn child. Medical personnel are often unaware of the important effect of specific reproductive patterns on fetal and neonatal mortality. Most of the differences in the magnitude of the effect of specific FFP on childhood mortality can probably be explained by the accessibility and quality of perinatal care. Scores used in order to identify high-risk women include high parity and old age as risk factors. A revision of the variables associated with reproduction is strongly recommended. Previous negative outcomes, short spacing, and fast reproductive pace are likely to be much more sensitive, and specific indicators for the identification of women at high risk.

Antenatal care for women with reproductive patterns associated with high neonatal mortality is likely to prevent several deaths. However, it should be accompanied by delivery and neonatal care of high quality. More research is needed in order to determine which are the specific diseases and causes of death associated with births from fast reproducing women and with poorly-spaced births.

Rural women with less than three years of schooling are, by far, the group with the highest risk, both because they have an unfavorable reproductive pattern and because they have less access to appropriate medical care. It is strongly recommended that the new phase of the family planning program should be accompanied by high quality prenatal, delivery, and neonatal care. The integration of family planning activities with maternal and child health care ranks very high in the health priorities and constitutes an urgent policy reform in the Mexican context.

## REFERENCES

- Baird, D. and A. M. Thompson. 1969. "General factors underlying perinatal mortality rates." In Perinatal Problems. Eds. N. R. Butler and E. Alberman. Edinburgh and London: E. and S. Livingstone.
- Becker, S. and H. Hiltabidle. 1981. "Comparison of measures at childbearing: Patterns by age and parity in Matlab, Bangladesh." Working Paper No. 115 of the International Centre for Diarrhoeal Disease Research, Bangladesh.
- Behm Rosas, H. 1985. "Sobrevivencia en la infancia: Las dimensiones del problema en América Latina." Documento de Trabajo No. 17. México D.F., México: The Population Council.
- Bobadilla, J. L. 1985. "Evaluación de la calidad de los datos sobre mortalidad perinatal. Encuesta Mexicana de Fecundidad 1976-1977." Salud Pública de México 27,15: 454-468.
- Bobadilla, J. L. 1987. "The effects of family formation patterns on perinatal health." Paper presented at the International Conference on Better Health for Women and Children through Family Planning held in Nairobi, Kenya, October 5-9, 1987, sponsored by IPPF, the Population Council, UNCHF, UNDP, UNFPA, and The World Bank.
- Bobadilla, J. L. 1988. "Quality of perinatal medical care in Mexico City." Perspectivas en Salud Pública No. 3 Mexico, D.F.: INSP.
- Frenk J., T. Frejka, J. L. Bobadilla, C. Stern et al. 1989. "The epidemiologic transition in Latin America." In XXIV International Population Conference, Proceedings, IUSSP, New Delhi.
- De Alba, R. 1988. "Interpreting the parameters of a log-linear model." In Common Problems, Proper Solutions. Ed. S. Long. Beverly Hills and London: Sage Press.
- General Directorate of Statistics of the National Institute of Statistics, Geography, and Informatics. "1989 Lists of Vital Statistics" (unpublished).
- Geronimus, A. J. 1986. "The effect of race, residence, and prenatal care on the relationship of maternal age and neonatal mortality." American Journal of Public Health 76: 1416-1421.
- Hobcraft, J. N., J. W. McDonald, and S. D. Rutstein. 1985. "Demographic determinants of infant and early child mortality: A comparative analysis." Population Studies 39: 363-385.
- Hobcraft, J. N. 1987. "Does family planning save children's lives?" WHO Technical Background Paper prepared for the International Conference on Better Health for Women and Children through Family Planning held in Nairobi, Kenya, October 5-9, 1987 sponsored by IPPF, the Population Council, UNCHF, UNDP, UNFPA, and The World Bank.
- McCormick, M., S. Shapiro, and B. Starfield. 1984. "High risk young mothers: Infant mortality and morbidity in four areas in the United States, 1973-1978." American Journal of Public Health 1974: 18-23.
- Mier y Terán, M. 1987. "Some aspects of the interrelationship between fertility patterns and health: The case of Mexico." World Health Statistics Quarterly 40: 41-53.
- Omran, A. R. and C. C. Standley. 1981. "Review of the evidence." In Further Studies on Family Formation Patterns and Health. Eds. R. Omram and C. C. Standley. Geneva: World Health Organization.

- Ordorica M. and J. E. Potter. 1981. "Evaluation of the Mexican Fertility Survey 1976-1977." WFS Scientific Reports No. 21.
- Paneth, N., S. Wallenstein, J. Kiely, and M. Susser. 1982. "Social class indicators and mortality in low birthweight infants." American Journal of Epidemiology 116: 364-375
- Pebbley A. R. and S. Millman. 1986. "Birthspacing and child survival." International Family Planning Perspectives. 12,3: 71-79.
- Puffer, R. R. and C. V. Serrano. 1975. "Birthweight, maternal age, and birth order: Three important determinants in infant mortality." Scientific Publication No. 294. Washington, D. C.: Pan American Health Organization.
- Rutstein, S. O. 1983. "Infant and child mortality: Levels, trends and demographic differentials." WFS Comparative Studies No. 24.
- Sepulveda, J., W. Willett, and A. Munoz. 1988. "Malnutrition and diarrhea: A longitudinal study among urban Mexican children." American Journal of Epidemiology 127,2: 365-376.
- Shah, F. K. and H. Abbey. 1971. "The effects of family formation patterns on perinatal health." Proceedings of the International Conference on Better Health for Women and Children through Family Planning, volume in press.
- SSA (Ministry of Health). 1988a. "Encuesta nacional sobre fecundidad y salud 1987." Memoria de la Reunión Celebrada el 30 de septiembre de 1988. SSA Dirección General de Planificación Familiar, México, D. F.: SSA (Ministry of Health).
- \_\_\_\_\_. 1988b. "Encuesta nacional sobre fecundidad y salud 1987." Memoria de la Reunión Celebrada el 27 y 28 de octubre de 1988. SSA Dirección General de Planificación Familiar, México, D. F.: SSA (Ministry of Health).
- \_\_\_\_\_. 1988c. "Encuesta nacional sobre fecundidad y salud 1987." Memoria de la Reunión Celebrada el 18 de febrero de 1988. SSA Dirección General de Planificación Familiar, México, D. F.: SSA (Ministry of Health).
- Winikoff, B. 1983. "The effects at birth spacing on child and maternal health." Studies in Family Planning. 14,10: 231-245.
- Winikoff, B. and M. A. Castle. 1987. "The maternal depletion syndrome: Clinical diagnosis or eco-demographic condition?" WHO Technical Background Paper prepared for the International Conference on Better Health for Women and Children through Family Planning held in Nairobi, Kenya, October 5-9, 1987 sponsored by IPPF, the Population Council, UNCHF, UNDP, UNFPA, and The World Bank.

## **APPENDIX A: Definitions of Terms**

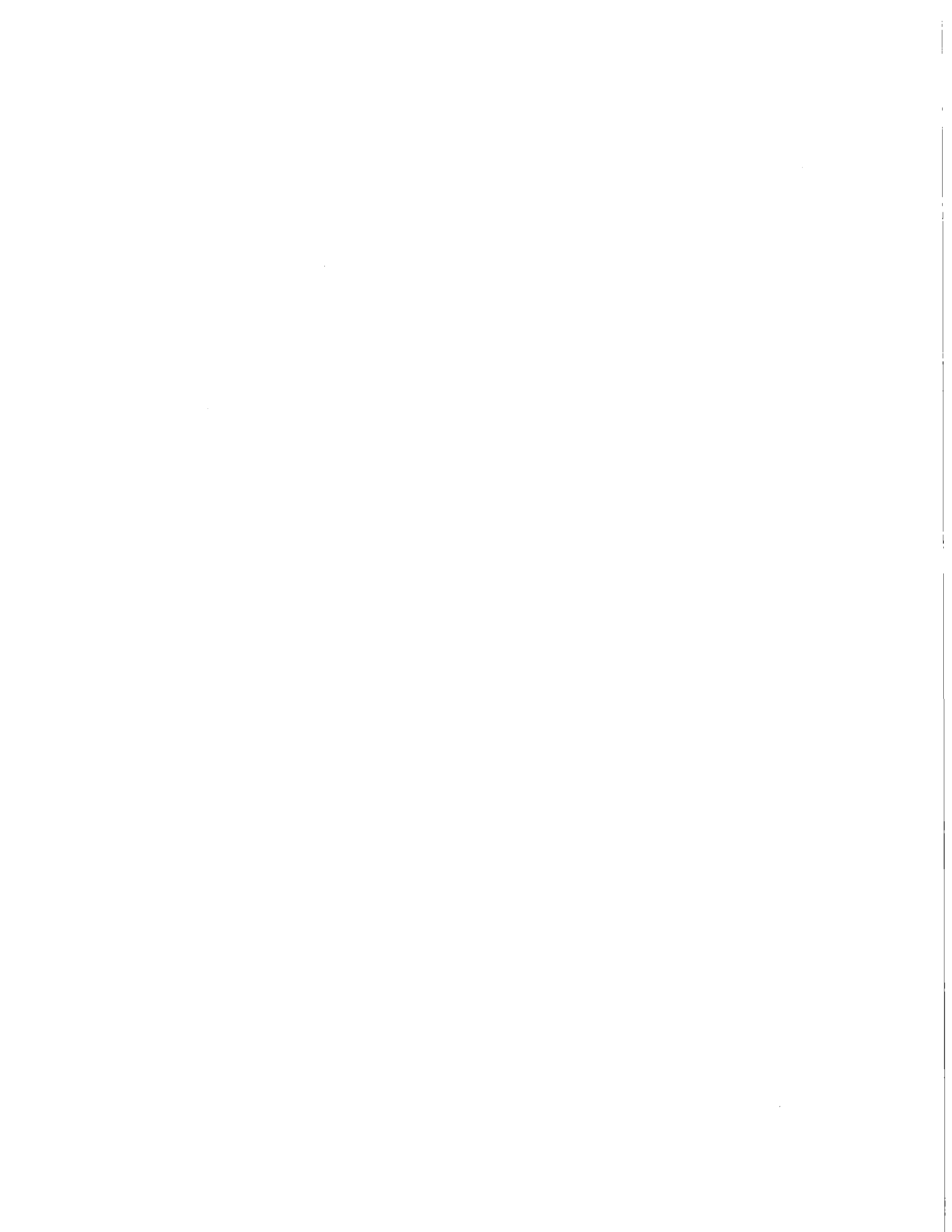

## APPENDIX A: Definitions of Terms

Abortions: Losses before the sixth month of gestation.

Births: Products of pregnancies that occur from the sixth month of gestation onwards. They include both late fetal deaths and live births.

Live births (LB): Products of gestation born alive. They include those originally reported as stillbirths but for which, subsequently, the mother reported some signs of life.

Late fetal deaths (LFD): Losses from the sixth month of gestation onwards. In fact, late fetal deaths are those occurring after the 28th week of gestation. However, since the information on the time of occurrence of the loss was asked in terms of months of gestation, the above definition had to be adopted.

Neonatal deaths (ND): Live births who died in the first month of life. In fact, neonatal deaths include only those occurring in the first 28 days of life. However, information on the age at death was not asked with precision.

Postneonatal deaths (PND): Live births who died at ages 1 to 11 months.

Infant deaths (ID): Live births who died in the first year of life, i.e., 0-11 months of age. Infant deaths = neonatal + postneonatal deaths.

Preschool deaths (PSD): Live births who died at ages 1 to 4 years.

Childhood deaths (CHD): Live births who died in the first 5 years of life, i.e., 0-59 months of age.  
Childhood deaths = infant + preschool deaths.

$$\text{Late fetal mortality rate (LFMR)} = \frac{\text{LFD}}{\text{LB} + \text{LFD}} \times 1,000$$

$$\text{Neonatal mortality rate (NMR)} = \frac{\text{ND}}{\text{LB}} \times 1,000$$

$$\text{Postneonatal mortality rate (PNMR)} = \frac{\text{PND}}{\text{LB} - \text{ND}} \times 1,000$$

$$\text{Infant mortality rate (IMR)} = \frac{\text{ID}}{\text{LB}} \times 1,000$$

$$\text{Preschool mortality rate (PSMR)} = \frac{\text{PSD}}{\text{LB} - \text{ID}} \times 1,000$$

$$\text{Childhood mortality rate (CHMR)} = \frac{\text{CHD}}{\text{LB}} \times 1,000$$



Reproductive pace: Was estimated according to the number of births adjusted for the age of the mother at the time of the birth of the index child, as follows:

	Age (in years)	Births
<b>Slow, if:</b>	20-24	2
	25-29	2-3
	30-34	2-4
<b>Medium, if:</b>	20-24	3
	25-29	4-5
	30-34	5-6
<b>Fast, if:</b>	20-24	4+
	25-29	6+
	30-34	7+

**APPENDIX B: Tables**



**TABLE 1**  
**LATE FETAL MORTALITY RATES IN MEXICO ACCORDING TO ENFES (1987) AND IN**  
**MEXICO AND THE FEDERAL DISTRICT ACCORDING TO VITAL STATISTICS**  
**1972-1986**

PERIOD	MEXICO		FEDERAL DISTRICT. VITAL STATISTICS
	ENFES	VITAL STATISTICS	
1972 - 1976	12.17	13.70 <sup>a</sup>	15.79
1977 - 1981	21.83	10.66	12.80 *
1982 - 1986	15.52	8.27 **	(4.87) <sup>b</sup> **

RATES BY 1000 LIVE BIRTHS + LATE FETAL DEATHS

\* 1977 - 1979

\*\* 1982 - 1984

a) For the years 1972 and 1973, the fetal deaths of the Mexican Republic that did not have a specified gestational age were included in the late fetal death category. The resulting overestimation is about 2-3%, if a similar percentage of non specification is assumed as for later years.

b) The late fetal mortality rate has been reported to be 16 per thousand in a large study of 32,700 births in 25 hospitals in Mexico City (Bobadilla, 1988). The vital statistics figure for the period 1982-1984, therefore, underestimates the real rate.

TABLE 2

NEONATAL, POSTNEONATAL AND INFANT MORTALITY IN MEXICO  
AND THE FEDERAL DISTRICT ACCORDING TO ENFES (1987) AND  
THE VITAL STATISTICS

NEONATAL MORTALITY RATES

PERIOD	MEXICO		FEDERAL DISTRICT	
	ENFES	VITAL STATISTICS	VITAL STATISTICS	
1972 - 1976	37.2	20.04	26.28	
1977 - 1981	28.6	18.61 *	23.28 *	
1982 - 1986	24.8	11.66 **	14.09 **	

POSTNEONATAL MORTALITY RATES

PERIOD	MEXICO		FEDERAL DISTRICT	
	ENFES	VITAL STATISTICS	VITAL STATISTICS	
1972 - 1976	29.81	32.26	31.06	
1977 - 1981	30.91	26.26 *	15.80 *	
1982 - 1986	18.56	15.59 **	12.65 **	

INFANT MORTALITY RATES

PERIOD	MEXICO		FEDERAL DISTRICT	
	ENFES	VITAL STATISTICS	VITAL STATISTICS	
1972 - 1976	65.87	51.69	50.84	
1977 - 1981	58.65	40.09	37.44	
1982 - 1986	42.92	29.25 *	29.39 *	

\* 1977-1978  
\*\* 1984-1985  
\*\*\* 1982-1985

**TABLE 3**

**PRESCHOOL AND CHILDHOOD MORTALITY IN MEXICO AND  
THE FEDERAL DISTRICT ACCORDING TO ENFES  
(1987) AND THE VITAL STATISTICS**

**PRESCHOOL MORTALITY RATES**

PERIOD	MEXICO		FEDERAL DISTRICT
	ENFES	VITAL STATISTICS	VITAL STATISTICS
1972 - 1976	16.97	19.85	8.37 *
1977 - 1981	12.55	13.32	4.34
1982 - 1986	-	8.86 **	3.46 **

RATE BY 1000 SURVIYORS OF THE INFANT PERIOD

**CHILDHOOD MORTALITY RATES**

PERIOD	MEXICO		FEDERAL DISTRICT
	ENFES	VITAL STATISTICS	VITAL STATISTICS
1972 - 1976	81.73	70.51	70.06 *
1977 - 1981	70.46	52.87	41.68
1982 - 1986	-	37.86 **	32.75 **

RATES BY 1000 LIYE BIRTHS

\* 1972 - 1975

\*\* 1982 - 1985

TABLE 4

DISTRIBUTION OF BIRTHS OCCURRING BETWEEN 1 AND 14 COMPLETED YEARS PRIOR TO THE SURVEY TO WOMEN ACROSS 11 FAMILY FORMATION PATTERNS FOR DIFFERENT TIME PERIODS (EMFES 1987)

FFP PERIODS	T E E N				20 - 34 YEARS								35 +	TOTAL		
	FIRST BIRTHS	LATER BIRTHS		FIRST BIRTHS	SLOW	MEDIUM		SLOW	WELL SPACED	POORLY SPACED	WELL SPACED	POORLY SPACED			WELL SPACED	POORLY SPACED
		WELL SPACED	POORLY SPACED			WELL SPACED	POORLY SPACED									
1972-1976	11.0	1.7	4.9	12.4	10.5	10.8	10.5	10.5	10.5	10.8	10.5	10.5	8.8	12.4	6.5	100.0
1977-1981	10.8	2.0	4.5	13.4	13.6	9.5	10.7	8.5	10.7	9.5	8.5	7.5	7.5	8.4	11.1	100.0
1982-1986	9.2	1.6	3.0	13.4	18.2	9.0	13.1	7.4	13.1	9.0	7.4	6.8	6.8	6.7	11.7	100.0
TOTAL N	1371	236	552	1731	1854	1287	1505	1160	1505	1287	1160	1018	1018	1206	1297	13216
%	10.4	1.8	4.2	13.1	14.0	9.7	11.4	8.8	11.4	9.7	8.8	7.7	7.7	9.1	9.8	100.0

TABLE 5

PERCENTAGE DISTRIBUTION OF BIRTHS TO WOMEN AGED UNDER 35 ACROSS 10 FAMILY FORMATION PATTERNS, ONE TO 14 COMPLETED YEARS PRIOR OF THE SURVEY: COMPARISON OF LATIN AMERICAN COUNTRIES

FFP	T E E N				20 - 34 YEARS										TOTAL SAMPLE SIZE
	FIRST BIRTHS	LATER BIRTHS			FIRST BIRTHS	LATER BIRTHS						FAST POORLY SPACED			
		WELL SPACED	POORLY SPACED	POORLY SPACED		WELL SPACED	SLOW		MEDIUM		WELL SPACED		POORLY SPACED		
							WELL SPACED	POORLY SPACED	WELL SPACED	POORLY SPACED					
COLOMBIA	11.3	2.1	5.9	11.1	10.7	10.2	9.9	11.6	9.9	9.9	11.6	9.9	17.2	100.0	
COSTA RICA	10.0	1.3	5.2	13.7	11.8	9.9	9.8	10.6	9.0	9.0	10.6	9.0	18.7	100.0	
PANAMA	10.7	2.3	5.8	12.4	12.7	10.0	12.8	10.5	10.2	10.2	10.5	10.2	12.6	100.0	
PERU	9.8	1.9	4.0	10.9	14.3	10.1	14.5	11.2	10.5	10.5	11.2	10.5	12.7	100.0	
MEXICO	11.5	2.0	4.6	14.5	15.6	10.8	12.6	9.7	8.5	8.5	9.7	8.5	10.1	100.0	

SOURCES. For Mexico: Elaborated by the authors, based on the ENFES (1987)  
 For Colombia, Costa Rica, Panamá and Perú: Elaborated by Hoberaff (1987), based on national data from the World Fertility Survey.

Note: For Mexico the reference period is 1972-1986; for the other countries, any period between 1961 and 1975.



**TABLE 6**  
**DISTRIBUTION OF BIRTHS OCCURRED BETWEEN 1 AND 14 COMPLETED YEARS PRIOR TO THE SURVEY TO**  
**WOMEN ACROSS 11 FAMILY FORMATION PATTERNS BY SCHOOLING OF THE MOTHER AT THE**  
**TIME OF THE SURVEY**  
**(ENFES 1987)**

FFP SCHOOLING (YRS)	T E E N				20 - 34 YEARS								35 +		TOTAL
	FIRST BIRTHS	LATER BIRTHS		FIRST BIRTHS	LATER BIRTHS				FIRST BIRTHS	LATER BIRTHS		FIRST BIRTHS	LATER BIRTHS		
		WELL SPACED	POORLY SPACED		SLOW	MEDIUM	FAST	WELL SPACED		POORLY SPACED					
0	7.1	4.1	4.1	5.4	8.3	6.0	13.2	8.6	14.0	13.0	14.0	18.1	100.0		
1-3	8.8	2.1	5.7	6.9	10.0	8.1	13.9	8.6	12.2	10.4	10.8	100.0			
4-6	12.1	1.7	4.1	15.3	16.0	11.1	11.3	8.9	7.2	5.5	6.7	100.0			
7+	13.7	0.7	1.9	28.5	24.1	14.5	5.2	5.0	1.7	0.9	3.7	100.0			
TOTAL	10.4	1.8	4.2	13.1	14.0	9.7	11.4	8.8	7.7	9.1	9.8	100.0			
AVERAGE SCHOOLING	5.0	3.1	3.7	6.6	5.9	5.2	3.5	3.8	2.5	2.8	2.6	4.2			

TABLE 7

DISTRIBUTION OF BIRTHS OCCURRED BETWEEN 1 AND 15 YEARS PRIOR TO THE SURVEY TO WOMEN ACROSS 11 FAMILY FORMATION PATTERNS BY SIZE OF THE COMMUNITY OF RESIDENCE OF THE MOTHER AT THE TIME OF THE SURVEY (ENFES 1987)

FFP COMMUNITY SIZE (INHABS.)	T E E N			20 - 34 YEARS						35 +	TOTAL	
	FIRST BIRTHS	LATER BIRTHS		FIRST BIRTHS	LATER BIRTHS			FAST				
		WELL SPACED	POORLY SPACED		WELL SPACED	POORLY SPACED	SLOW	MEDIUM	WELL SPACED			POORLY SPACED
<2,500	9.6	2.5	5.4	7.5	9.7	7.6	13.4	9.3	10.7	12.5	11.6	100.0
2,500-19,999	9.5	1.6	4.1	11.1	12.8	9.8	12.5	9.8	7.1	10.3	11.5	100.0
20,000 +	10.9	1.8	3.4	17.1	17.1	10.8	9.9	8.5	5.9	6.1	8.5	100.0
METROP. (1) AREAS	11.7	0.8	2.9	19.8	19.1	12.2	8.6	7.4	5.0	5.7	6.9	100.0
TOTAL	10.4	1.8	4.2	14.0	13.1	9.7	11.4	8.8	7.7	9.1	9.8	100.0

(1) Include the metropolitan areas of Mexico City, Guadalupe and Monterrey, all with more than 1,000,000 inhabitants.

**TABLE 8**  
**NEONATAL, POSTNEONATAL AND INFANT MORTALITY RATES:**  
**COMPARISON BETWEEN ENFES (1987) AND EMF (1976) \***

MORTALITY RATE	ENFES 1972-1976	EMF 1971-1976	DIFFERENCE WITH EMF (%)
NEONATAL	37.2	41.6	11.8
POSTNEONATAL	29.8	28.0	6.0
INFANT	65.9	69.5	5.6

\* Mexican Fertility Survey

TABLE 9  
MORTALITY RATES DURING CHILDHOOD BY SCHOOLING OF THE MOTHER AT  
THE TIME OF THE SURVEY  
(ENFES 1987)

MORTALITY RATES / SCHOOLING (YRS)	1	2	3	2	4	5
	LATE FETAL	NEONATAL	POST- NEONATAL	INFANT	PRESCHOOL	CHILDHOOD
0	22.5	42.8	37.2	78.0	31.4	111.5
1-2	22.7	33.8	29.6	62.4	22.0	84.7
4-6	15.8	20.0	24.1	43.6	6.3 *	54.3
7+	14.4	17.5 *	11.6	28.8	1.5 *	40.7
TOTAL	18.7	28.3	26.2	53.8	15.8	74.4

- 1: Per 1000 Births: 1977-1986
- 2: Per 1000 live births: 1972-1986
- 3: Per 1000 survivors to the neonatal period: 1972-1986
- 4: Per 1000 survivors to the infant period: 1972-1982
- 5: Per 1000 live births: 1972-1982

\* Less than 50 deaths

**TABLE 10**  
**MORTALITY RATES DURING CHILDHOOD BY AGE OF THE MOTHER AT**  
**THE BIRTH OF THE INDEX CHILD**  
**(ENFES 1987)**

MORTALITY RATES AGE (YRS)	1 LATE FETAL	2 NEONATAL	3 POST- NEONATAL	2 INFANT	4 PRESCHOOL	5 CHILDHOOD
< 20	18.8	30.1	35.8	64.8	14.2 *	86.1
20-34	16.6	28.3	24.5	52.0	15.6	72.6
35+	30.3	26.2 *	23.8 *	49.3	20.2 *	66.2
TOTAL	18.9	28.3	26.2	53.8	15.8	74.4

- 1: Per 1000 births: 1977-1986
- 2: Per 1000 live births: 1972-1986
- 3: Per 1000 survivors to the neonatal period: 1972-1986
- 4: Per 1000 survivors to the infant period: 1972-1982
- 5: Per 1000 live births: 1972-1982

\* Less than 50 deaths

TABLE 11

MORTALITY RATES DURING CHILDHOOD BY PARITY OF THE MOTHER AT THE BIRTH OF THE INDEX CHILD (ENFES 1987)

MORTALITY RATES BIRTH ORDER	1 LATE FETAL	2 NEONATAL	3 POST-NEONATAL	2 INFANT	4 PRESCHOOL	5 CHILDHOOD
FIRST BIRTH	16.3	20.9	18.3	38.8	7.2 *	51.8
SUBSEQUENT	18.1	30.9	29.0	58.9	18.6	81.5
ORDER: 2	-	18.5 *	28.1	46.1	16.1 *	68.2
3	-	29.9	23.7 *	52.9	9.4 *	64.8
4	-	41.6	31.5 *	71.0	14.8 *	99.7
5	-	30.8 *	28.2 *	58.1	28.0 *	81.9
6+	-	37.0	31.7	67.6	25.8 *	95.2
TOTAL	17.6	28.3	26.2	53.8	15.8 *	74.4

- 1: Per 1000 births: 1977-1986
- 2: Per 1000 live births: 1972-1986
- 3: Per 1000 survivors to the neonatal period: 1972-1986
- 4: Per 1000 survivors to the infant period: 1972-1982
- 5: Per 1000 live births: 1972-1982

\* Less than 50 deaths

TABLE 12

MORTALITY RATES DURING CHILDHOOD BY REPRODUCTIVE PACE OF THE MOTHER AT THE BIRTH OF THE INDEX CHILD (ENFES 1987)

MORTALITY RATES PACE	1 LATE FETAL	2 NEONATAL	3 POST-NEONATAL	2 INFANT	4 PRESCHOOL	5 CHILDHOOD
SLOW	13.8	20.1	19.2	38.8	23.1 *	53.8
MEDIUM	14.9	24.0	33.8	56.7	30.8 *	79.8
FAST	24.5	54.0	30.9	83.6	36.7 *	111.6
TOTAL	18.6	30.8	27.2	57.2	15.8	79.9

- 1: Per 1000 births: 1977-1986
- 2: Per 1000 live births: 1972-1986
- 3: Per 1000 survivors to the neonatal period: 1972-1986
- 4: Per 1000 survivors to the infant period: 1972-1982
- 5: Per 1000 live births: 1972-1982

\* Less than 50 deaths

**TABLE 13**  
**MORTALITY RATES DURING CHILDHOOD BY BIRTH SPACING WITH**  
**PREVIOUS SIBLING**  
**(ENFES 1987)**

MORTALITY RATES INTERVAL (MONTHS)	1 LATE FETAL	2 NEONATAL	3 POST- NEONATAL	2 INFANT	4 PRESCHOOL	5 CHILDHOOD
7-11	69.3*	55.3 *	63.5 *	113.7	25.8 *	142.6
12-23	19.0	37.1	37.0	72.7	20.9	95.6
24-35	10.4	27.1	26.1	52.1	21.0 *	79.8
36+	18.0*	18.6 *	12.4 *	31.1	10.5 *	40.5
TOTAL	18.6	26.3	26.2	53.8	15.8	74.4

- 1: Per 1000 births: 1977-1986
- 2: Per 1000 live births: 1972-1986
- 3: Per 1000 survivors to the neonatal period: 1972-1986
- 4: Per 1000 survivors to the infant period: 1972-1982
- 5: Per 1000 live births: 1972-1982

\* Less than 50 deaths



**TABLE 14**  
**DEATH RATES OF INFANTS BORN TO WOMEN ACROSS 11 FAMILY FORMATION PATTERNS (ENFES 1987)**

FFP DEATH RATES	T E E N			20 - 34 YEARS						35 +	TOTAL			
	FIRST BIRTHS	LATER BIRTHS		FIRST BIRTHS	LATER BIRTHS			FAST						
		WELL SPACED	POORLY SPACED		WELL SPACED	POORLY SPACED	SLOW	MEDIUM	WELL SPACED			POORLY SPACED		
LATE FETAL <sup>1</sup>	20.6	11.7	(20.1)	(15.8)	11.6	17.5	6.8	25.2	12.0	36.3	29.6	19.0		
NEONATAL	25.5	(16.9)	47.1	16.8	20.5	19.4	16.6	32.8	36.3	68.8	26.2	28.3		
POST-NEONATAL <sup>2</sup>	26.9	(25.9)	(62.7)	11.8	8.3	34.9	31.8	36.5	23.4	37.4	23.8	26.2		
INFANT <sup>3</sup>	51.8	(42.4)	106.8	28.3	28.6	53.6	47.8	68.1	58.9	103.6	49.3	53.8		
PRESCHOOL <sup>4</sup>	8.6	(30.3)	(21.2)	6.1	12.0	12.6	18.6	18.8	20.4	27.5	20.3	15.8		
CHILDHOOD <sup>5</sup>	67.5	(64.3)	(135.8)	38.9	43.8	67.1	72.2	88.3	91.8	128.5	66.2	74.4		

1. Per 1000 live births + stillbirths : 1977-1986  
2. Per 1000 live births : 1972-1986  
3. Per 1000 survivors to the neonatal period: 1972-1986  
4. Per 1000 survivors to the infant period: 1972-1982  
5. Per 1000 live births : 1972-1982  
Note: ( ) Less than 500 births

TABLE 15

RELATIVE RISK OF DYING OF INFANTS BORN TO WOMEN ACROSS 11 FAMILY FORMATION PATTERNS AGAINST THE TOTAL POPULATION (ENFES 1987)

FFP DEATH RATES	T E E M			20 - 34 YEARS						35 +	TOTAL	
	FIRST BIRTHS	LATER BIRTHS		FIRST BIRTHS	LATER BIRTHS			FAST				
		WELL SPACED	POORLY SPACED		WELL SPACED	POORLY SPACED	SLOW		MEDIUM			POORLY SPACED
<sup>1</sup> LATE FETAL	1.1	0.6	(1.1)	(0.8)	0.6	0.9	0.4	1.3	0.6	1.9	1.6	1.0
NEONATAL	0.9	(0.6)	1.7	0.2	0.7	0.7	0.6	1.2	1.3	2.4	0.9	1.0
POST-NEONATAL	1.0	(1.0)	(2.4)	0.5	0.3	1.3	1.2	1.4	0.9	1.4	0.9	1.0
INFANT	1.0	(0.8)	2.0	0.5	0.5	1.0	0.9	1.3	1.1	1.9	0.9	1.0
PRESCHOOL	0.5	(1.9)	(1.3)	0.4	0.8	0.8	1.2	1.2	1.3	1.7	1.3	1.0
CHILDHOOD	0.9	(0.8)	(1.8)	0.5	0.6	0.9	1.0	1.2	1.2	1.7	0.9	1.0

1. Per 1000 live births + stillbirths : 1977-1986
  2. Per 1000 live births : 1972-1986
  3. Per 1000 survivors to the neonatal period: 1972-1986
  4. Per 1000 survivors to the infant period: 1972-1982
  5. Per 1000 live births : 1972-1982
- Note: ( ) Less than 500 births

**TABLE 16**  
**ESTIMATED RELATIVE RISKS OF DYING IN INFANCY FOR BIRTHS OCCURRING BETWEEN**  
**1 AND 15 YEARS PRIOR TO THE SURVEY TO WOMEN ACROSS 11 FAMILY FORMATION**  
**PATTERNS, WITH REFERENCE TO THE TOTAL POPULATION \***  
**(ENFES 1987)**

MODEL	TEEN LATER BIRTHS		20 - 34 YEARS LATER BIRTHS						35 +	BASELINE ODDS
	FIRST BIRTHS	POORLY SPACED	SLOW		MEDIUM		FAST			
			WELL SPACED	POORLY SPACED	WELL SPACED	POORLY SPACED	WELL SPACED	POORLY SPACED		
RAW RISKS	0.96	1.99	0.53	1.00	0.89	1.27	1.1	1.93	0.92	-
1	0.96	2.10	0.51	1.00	0.89	1.29	1.11	2.03	0.91	.0572
2	1.33	2.17	1.14	0.95	0.77	1.02	0.90	1.27	0.86	.0685
3	1.00	2.02	0.57	1.06	0.87	1.29	1.05	1.92	0.88	.0523
4	1.04	2.01	0.62	1.11	0.85	1.28	0.99	1.83	0.83	.0495

MODEL	VARIABLES	RELATIVE RISKS	
		SCHOOLING (YRS)	COMMUNITY SIZE (INHABS.)
1	FFP		
2	FFP, SCHOOLING	<3: 1.20 4-6: 0.95 7+: 0.88	
3	FFP, COMMUNITY SIZE		<2500: 1.37 2500-19,999: 1.14 20,000 +: 0.83 METROP. AREAS: 0.78
4	FFP, SCHOOLING, COMMUNITY SIZE	<3: 1.32 4-6: 0.97 7+: 0.79	<2500: 1.26 2500-19,999: 1.11 20,000 +: 0.86 METROP. AREAS: 0.83

\* The relative risks are estimated by taking the odds of death in one category to the geometric mean of odds of all categories.

**TABLE 17**  
**ESTIMATED RELATIVE RISKS OF DYING IN CHILDHOOD FOR BIRTHS OCCURRING BETWEEN 5 AND 15 YEARS PRIOR TO THE SURVEY TO WOMEN ACROSS 11 FAMILY FORMATION PATTERNS, WITH REFERENCE TO THE TOTAL POPULATION \* (ENFES 1987)**

MODEL	T E E M		20 - 34 YEARS												35 +	BASELINE ODDS
	FIRST BIRTHS	LATER BIRTHS	LATER BIRTHS						FAST							
			WELL SPACED	POORLY SPACED	WELL SPACED	POORLY SPACED	WELL SPACED	POORLY SPACED	WELL SPACED	POORLY SPACED	WELL SPACED	POORLY SPACED	WELL SPACED	POORLY SPACED		
RAW RISKS	0.91	0.86	1.83	0.52	0.59	0.90	0.97	1.19	1.23	1.73	0.89	-				
1	0.91	0.91	1.97	0.50	0.57	0.89	0.98	1.21	1.25	1.83	0.88	.0806				
2	1.28	0.92	1.90	0.83	0.56	0.85	1.16	0.93	1.12	1.14	0.82	.0920				
3	0.95	0.81	1.88	0.58	0.63	0.97	0.94	1.21	1.19	1.72	0.86	.0728				
4	0.99	0.79	1.98	0.63	0.65	1.02	0.92	1.21	1.12	1.65	0.80	.0693				

MODEL	VARIABLES	RELATIVE RISKS	
		SCHOOLING (YRS)	COMMUNITY SIZE (INHABS.)
1	FFP		
2	FFP, SCHOOLING	<3: 1.09 4-6: 1.07 7+: 0.85	
3	FFP, COMMUNITY SIZE		<2500: 1.43 2500-19,999: 1.27 20,000 +: 0.76 METROP. AREAS: 0.72
4	FFP, SCHOOLING, COMMUNITY SIZE	<3: 1.35 4-6: 0.90 7+: 0.93	<2500: 1.31 2500-19,999: 1.23 20,000 +: 0.79 METROP. AREAS: 0.79

\* The relative risks are estimated by taking the odds of death in one category to the geometric mean of odds of all categories.

**TABLE 18**  
**ODDS OF DEATH IN INFANCY FOR ALL POSSIBLE COMBINATIONS OF MATERNAL EDUCATION AND COMMUNITY SIZE FOR BIRTHS OCCURRING BETWEEN 1 AND 15 YEARS PRIOR TO THE SURVEY TO WOMEN ACROSS 11 FAMILY FORMATION PATTERNS (EFES 1987)**

FFP EDUCATION COMM. SIZE	T E E N				20 - 34 YEARS						35 +		
	FIRST BIRTHS		LATER BIRTHS		FIRST BIRTHS		LATER BIRTHS		LATER BIRTHS			FAST	
	WELL SPACED	POORLY SPACED	WELL SPACED	POORLY SPACED	WELL SPACED	POORLY SPACED	WELL SPACED	POORLY SPACED	WELL SPACED	POORLY SPACED		WELL SPACED	POORLY SPACED
<u>≤ 3 YEARS</u>													
< 2500	1.72	1.18	3.31	1.02	0.97	1.83	1.40	2.11	1.63	3.02	1.37		
2500-19,999	1.51	1.04	2.92	0.90	0.86	1.62	1.23	1.86	1.44	2.67	1.21		
20 000+	1.17	0.81	2.27	0.70	0.67	1.26	0.95	1.45	1.12	2.07	0.94		
METROP. AREAS	1.14	0.79	2.20	0.67	0.64	1.22	0.93	1.40	1.08	2.01	0.91		
<u>4-6 YEARS</u>													
< 2500	1.26	0.86	2.43	0.75	0.74	1.35	1.02	1.55	1.20	2.22	1.00		
2500-19,999	1.11	0.76	2.14	0.66	0.63	1.19	0.90	1.37	1.05	1.96	0.88		
20 000+	0.86	0.59	1.66	0.51	0.49	0.92	0.70	1.06	0.82	1.52	0.69		
METROP. AREAS	0.83	0.57	1.61	0.49	0.47	0.89	0.68	1.03	0.79	1.47	0.67		
<u>7+ YEARS</u>													
< 2500	1.02	0.70	1.98	0.61	0.58	1.10	0.83	1.26	0.97	1.81	0.82		
2500-19,999	0.90	0.62	1.74	0.53	0.51	0.97	0.73	1.11	0.86	1.59	0.72		
20 000+	0.70	0.48	1.35	0.41	0.40	0.75	0.57	0.86	0.67	1.24	0.56		
METROP. AREAS	0.68	0.47	1.31	0.40	0.38	0.73	0.55	0.84	0.64	1.20	0.54		

Baseline Odds: 0.0495

**TABLE 19**  
**ODDS OF DEATH IN CHILDHOOD FOR ALL POSSIBLE COMBINATIONS OF MATERNAL EDUCATION AND COMMUNITY SIZE FOR BIRTHS OCCURRING BETWEEN 1 AND 15 YEARS PRIOR TO THE SURVEY TO WOMEN ACROSS 11 FAMILY FORMATION PATTERNS (ENFES 1987)**

FFP EDUCATION COMM. SIZE	T E E N				20 - 34 YEARS						35 +	
	FIRST BIRTHS		LATER BIRTHS		FIRST BIRTHS		LATER BIRTHS		LATER BIRTHS		FAST	
	WELL SPACED	POORLY SPACED	WELL SPACED	POORLY SPACED	WELL SPACED	POORLY SPACED	WELL SPACED	POORLY SPACED	WELL SPACED	POORLY SPACED		
<u>≤ 3 YEARS</u>												
< 2500	1.74	1.38	3.30	1.10	1.14	1.78	1.61	2.12	1.97	2.90	1.29	
2500-19,999	1.63	1.30	3.11	1.03	1.07	1.67	1.51	1.99	1.85	2.73	1.31	
20 000+	1.05	0.84	2.00	0.66	0.69	1.07	0.97	1.28	1.19	1.75	0.84	
METROP. AREAS	1.05	0.84	2.00	0.66	0.69	1.08	0.97	1.28	1.19	1.75	0.84	
<u>4-6 YEARS</u>												
< 2500	1.15	0.92	2.20	0.73	0.76	1.18	1.07	1.41	1.31	1.93	0.93	
2500-19,999	1.09	0.87	2.07	0.68	0.71	1.11	1.01	1.32	1.23	1.81	0.87	
20 000+	0.70	0.56	1.33	0.44	0.46	0.71	0.65	0.85	0.79	1.17	0.56	
METROP. AREAS	0.70	0.56	1.33	0.44	0.46	0.71	0.65	0.85	0.79	1.17	0.56	
<u>7+ YEARS</u>												
< 2500	1.07	0.85	2.03	0.67	0.70	1.09	0.99	1.30	1.21	1.78	0.85	
2500-19,999	1.00	0.80	1.91	0.63	0.66	1.03	0.93	1.22	1.14	1.67	0.80	
20 000+	0.64	0.51	1.23	0.40	0.42	0.66	0.60	0.78	0.73	1.08	0.52	
METROP. AREAS	0.64	0.51	1.23	0.40	0.42	0.66	0.60	0.78	0.73	1.08	0.52	

Baseline Odds: 0.0693

TABLE 20

RELATIVE RISKS OF DEATH BY AGE FIVE\* ACROSS 10 FAMILY FORMATION PATTERNS, 1 TO 15 YEARS PRIOR TO THE SURVEY: COMPARISON OF 19 COUNTRIES

FFP	T E E N			20 - 34 YEARS						ALL BIRTHS	
	FIRST BIRTHS	LATER BIRTHS		FIRST BIRTHS	LATER BIRTHS			FAST		0	5
		WELL SPACED	POORLY SPACED		WELL SPACED	POORLY SPACED	SLOW	WELL SPACED	POORLY SPACED		
Ivory Coast	1.27	0.93	1.26	0.88	0.81	1.03	0.84	1.09	0.93	1.16	204
Senegal	1.06	1.04	1.22	0.79	0.94	0.65	1.02	1.02	1.00	1.02	262
Cameroon	1.05	1.00	1.27	1.09	0.71	1.31	0.74	1.36	0.94	1.33	196
Kenya	1.20	0.94	1.49	0.95	0.67	0.99	0.72	1.21	0.86	1.29	146
Lesoto	1.13	0.78	1.77	0.93	0.77	1.25	0.84	1.51	1.22	1.86	162
Morocco	1.21	0.66	1.60	0.77	0.75	1.03	0.58	1.33	0.75	1.46	151
Jordan	1.11	0.81	1.63	0.71	0.46	1.30	0.52	1.23	0.58	1.34	91
Bangladesh	1.22	0.85	1.41	0.87	0.66	1.30	0.68	1.36	0.69	1.31	214
Sri Lanka	1.23	1.01	1.49	0.74	0.84	0.84	0.84	1.25	1.04	1.48	79
Korea	1.37	-	-	1.00	0.77	1.08	0.87	2.10	1.15	2.73	71
Malaysia	1.07	1.14	1.95	0.80	0.80	0.77	0.86	1.05	0.96	1.41	56
Thailand	1.00	0.92	1.73	0.90	0.79	0.97	0.72	1.57	0.78	1.68	107
Colombia	0.94	1.21	1.66	0.67	0.80	1.07	0.63	1.09	0.64	1.40	101
Costa Rica	1.04	1.04	1.54	0.56	0.53	1.07	0.67	0.99	0.73	1.67	77
Panama	1.34	0.91	1.13	0.60	0.57	0.70	0.94	1.34	0.92	1.57	53
Peru	0.96	0.80	1.43	0.59	0.67	1.10	0.75	1.30	0.99	1.59	162
<b>MEXICO</b>	0.92	0.86	1.84	0.52	0.59	0.91	0.97	1.19	1.24	1.74	74
RAW RATIOS	0.99	0.79	1.88	0.63	0.65	1.02	0.92	1.21	1.24	1.65	74
ADJUSTED RATIOS	1.00	1.12	1.61	1.04	0.58	0.77	0.72	1.11	0.49	1.63	57
Jamaica	1.06	0.72	1.19	0.72	0.57	0.66	0.74	1.10	0.91	1.89	47

\* REFERENCE CATEGORY: ALL SAMPLE BIRTHS.  
 SOURCES: HOBDAFT (1987), ENFES (1987)

TABLE 21

RELATIVE RISK OF CHILD MORTALITY AMONG BIRTHS OF FAST REPRODUCING  
WOMEN ACCORDING TO THE SPACING OF BIRTHS IN 19 COUNTRIES

COUNTRIES		LEVEL OF MORTALITY	RELATIVE RISK (1) OF CHILDHOOD MORTALITY AMONG FAST REPRODUCERS	
			5 q 0	POORLY-SPACED
1st. group Moderate mortality 40-60	Trinidad/Tobago	47	2.87	1.59
	Panama	53	2.24	1.63
	Malaysia	56	1.84	1.20
	Jamaica	57	2.11	0.85
	Korea	71	2.55	1.49
	<b>México (2)</b>	<b>74</b>	<b>1.93</b>	<b>2.09</b>
	Costa Rica	77	1.55	1.37
	Sri Lanka	79	1.77	1.24
			$\bar{X} = 2.11$	$\bar{X} = 1.43$
2o. group High Mortality 81-180	Jordan	91	1.03	1.26
	Colombia	101	1.31	0.80
	Thailand	107	1.73	1.00
	Kenya	146	1.31	1.28
	Morocco	151	1.41	1.00
	Peru	162	1.44	1.48
	Lesotho	162	1.49	1.56
				$\bar{X} = 1.39$
3rd. group Very High Mortality 180-270	Cameron	196	1.01	1.32
	Ivory Coast	204	1.13	1.14
	Bangladesh	214	1.01	1.06
	Senegal	262	1.56	1.06
				$\bar{X} = 1.18$

SOURCES HOBcraft (1987), ENFES (1987)

- (1) The reference groups are the births to slow reproducers of each country
- (2) The data for Mexico refer to the period 1972-1981, whereas that of the other countries to 1962-1976